

47
YEARS
OF EXCELLENCE



NARAYANA
IIT-JEE/NEET/FOUNDATION

NEET (UG) 2026

SOLUTIONS
PAPER CODE -12

NARAYANA NATIONAL RESULT

MEDICAL MARVELS OF NARAYANA IN NEET 2025 ALL INDIA OPEN CATEGORY RANKS

MRINAL KISHORE JHA
nPrep

AIR **4**

KESHAV MITTAL
nPrep

AIR **7**

AASHI SINGH
nPrep

AIR **12**

SOMYA SHARMA
Classroom Student

AIR **14**

K JEEVAN SAI KUMAR
Classroom Student

AIR **18**

RUPAYAN PAL
nPrep

AIR **20**



ALL INDIA OPEN CATEGORY RANKS IN TOP 100

AIR

35



Kavish
nPrep

AIR

47



Rijul Jain
nPrep

AIR

49



Naveen Mittal
nPrep

AIR

52



Aditya Yadav
nPrep

AIR

59



D Surya Charan
Classroom Student

AIR

66

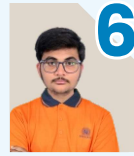

Devyansh Arora
Classroom Student

AIR

70



Y Sameer Kumar
Classroom Student

AIR

71



Maulik Bhalgamia
nPrep

AIR

73



Darshan Mule
nPrep

AIR

75



Yashashwi Kumar
nPrep

AIR

77



Armaan Bery
nPrep

AIR

80

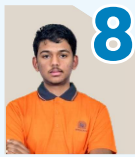

Diganth S
Classroom Student

AIR

87



Raghav Goyal
nPrep

AIR

93

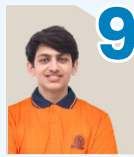

Siddh Vimalbhai Vora
Classroom Student

AIR

94



Shah Tejas Twinkle
nPrep

AIR

95

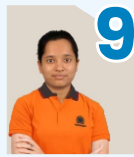

Bidisha Majee
Classroom Student

6 Students
in Top 20

22 Students
in Top 100

94 Students
in Top 1000



NARAYANA
IIT-JEE/NEET/FOUNDATION

NEET(UG) – 2026
(PAPER & SOLUTIONS)

PAPER CODE – 12

PHYSICS

1. A 100-turn closely wound circular coil of radius 5 cm has a magnetic field of 3.14×10^{-3} T at its centre. The current flowing through the coil, and the magnitude of the magnetic moment of this coil are, respectively :

(Take $\mu_0 = 4\pi \times 10^{-7}$ Tm / A)

- (1) 2.5 A, 2Am^2
(2) 2.5 A, 20Am^2
(3) 2 A, 4Am^2
(4) 2 A, 10Am^2

Ans. 1

Sol. $B = \mu_0 nI$

$$B = \frac{\mu_0 NI}{2r}$$

$$I = \frac{2rB}{\mu_0 N}$$

$$= \frac{2 \times 5 \times 10^{-2} \times 2.1 \times 10^3}{11 \times 10^{-7} \times 100}$$

$$\Rightarrow 2.5 \times 10^{-3} \times 10^5$$

$$\Rightarrow 2.5 \text{ A}$$

$$M = NIA$$

$$= 100 \times 2.5 \times 11 \times 25 \times 10^{-4}$$

$$= 62.5 \times 11 \times 10^{-2}$$

$$= 2 \text{ A}$$

2. Match List with List II:

	List I		List II
A.	$E = hv$	I.	de Broglie wavelength
B.	Diffraction and Interference	II.	Particle nature of light
C.	$\lambda = h / p$	III.	Wave nature of light
D.	Compton effect	IV.	Energy of photon

Choose the correct answer from the options given below:

- (1) A-IV, B-III, C-I, D-II
(2) A-I, B-IV, C-III, D-II
(3) A-IV, B-I, C-II, D-III
(4) A-IV, B-III, C-II, D-I

Ans. 1

Sol. Conceptual

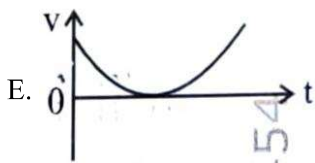

- (1) C only
 (2) A and E only
 (3) D only
 (4) B only

Ans. 1

Sol. Velocity is dec. then inc. in negative dir.

6. In a vernier callipers, 20 VSD coincide with 16 MSD (each division of length 1 mm). The least count of the vernier callipers is :

- (1) 0.01 cm
 (2) 0.1 cm
 (3) 0.02 cm
 (4) 0.2 cm

Ans. 3

Sol. $LC = 1 \text{ MSD} - \text{VSD}$,

$$\text{VSD} = \frac{16}{20} \text{MSD}$$

$$LC = 0.02 \text{ cm}$$

7. An ac circuit contains a resistance of $1\text{k}\Omega$, a capacitor of $0.1\mu\text{F}$ and an inductor of 1 mH connected in series. The resonance frequency of the circuit is approximately :

- (1) 10.1 kHz
 (2) 20.7 kHz
 (3) 15.9 kHz
 (4) 13.5 kHz

Ans. 3

Sol.

$$\Delta = \frac{1}{2\pi\sqrt{LC}}$$

$$= \frac{1}{2} \times \pi \sqrt{1 \times 10^{-3} \times 0.1 \times 10^{-6}}$$

$$\Rightarrow \frac{100000}{2\pi} \Rightarrow \frac{100}{2\pi} = 15.92 \text{ kHz}$$

8. The figure given below, shows a long straight solid wire of circular cross-section of radius 'a' carrying steady current I. The current I is uniformly distributed across its cross-section. The plot which correctly represents the variation of magnetic field (B) with distance (r) from the axis of the conductor in the region is :

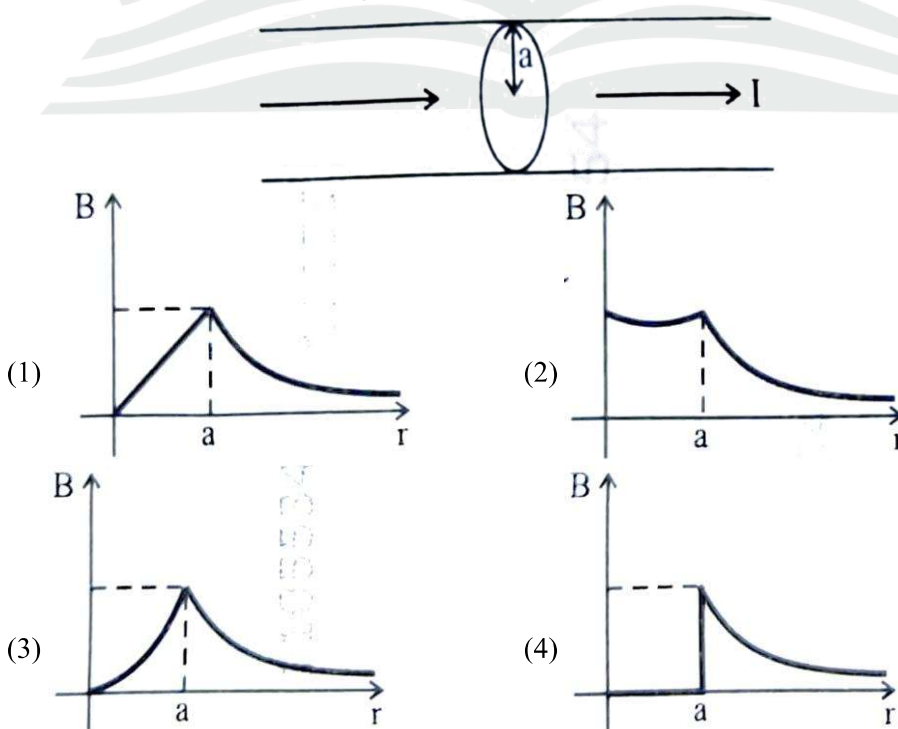

Ans. 1

Sol. $\oint \mathbf{B} \cdot d\mathbf{l} = \mu_0 I_{\text{enclosed}}$

$$B_{\text{inside}} \rightarrow B \cdot 2\pi x = \mu_0 \frac{I}{\pi R^2} \cdot \pi x^2$$

$$B = \frac{\mu_0 I}{2\pi R^2} x$$

$$B \text{ at side} \Rightarrow B_0 2\pi = \mu_0 I$$

$$\therefore B = \frac{\mu_0 I}{2\pi r}$$

$$B \times \frac{1}{r}$$

9. A uniform metallic wire having resistance 4Ω is bent to form a square loop (ABCD) (see figure). A resistance of 2Ω is connected between points B and D and a battery of $2V$ is connected across points A and C as shown in the figure. Now the value of current (I) is :

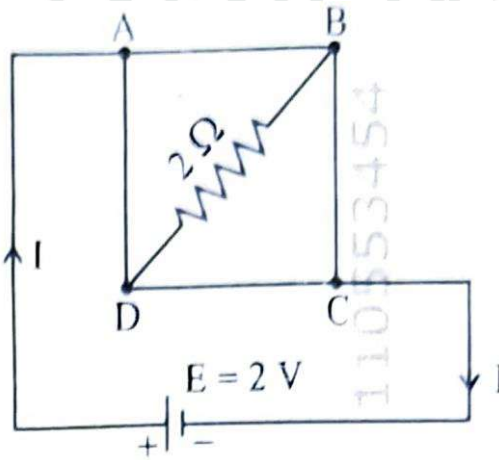

- (1) 2A
(2) 4A
(3) 8A
(4) 4.5A

Ans. 1

Sol. Balanced condition

$$R_{\text{eq}} = 2\Omega$$

$$i = \frac{2}{2} = 1A$$

10. An unknown nucleus has a nuclear density of $2.29 \times 10^{17} \text{ kg/m}^3$ and mass of $19.926 \times 10^{-27} \text{ kg}$. Its mass number A is approximately :

(Take $R_0 = 1.2 \times 10^{-15} \text{ m}$, $4\pi = 12.56$)

- (1) 12
(2) 19
(3) 20
(4) 16

Ans. 1

Sol. $m = 2.29 \times 10^{17} \times \frac{4}{3} \pi R^3$

$$R_0^3 = \frac{19.926 \times 10^{-27}}{2.29 \times 10^{17}} \times \frac{3}{4 \times 3.14}$$

$$\Rightarrow \frac{19.926 \times 10^{-27} \times 3}{2.29 \times 120.56}$$

$$19.926 \times 10^{-27} = 2.29 \times 10^{17} \times \frac{4}{3} \pi \times R^3$$

$$R^3 = \frac{19.926 \times 10^{-27} \times 3}{2.29 \times 4\pi \times 10^{17}}$$

$$= \frac{19.926 \times 3 \times 10^{-27} - 1.1}{2029 \times 12056} \Rightarrow 2.07 \times 10^{-44}$$

$$R = R_0 A v_3$$

$$A = \frac{R_0^3}{R_0^3} \Rightarrow \frac{2.07 \times 10^{-44}}{(1.2 \times 10^{-15})^3} \approx 12$$

11. A rectangular wire loop of sides 8 cm and 3 cm with a small cut, is moving out of a region of uniform magnetic field of magnitude 0.3 T directed normal to the plane of the loop. The emf developed across the cut, if the velocity of the loop is 2 cm s^{-1} , in a direction normal to the shorter side of the loop, will be :

- (1) 1.8×10^{-4} volt (2) 1.2×10^{-4} volt
(3) 1.3×10^{-4} volt (4) 4.8×10^{-4} volt

Ans. 1

Sol. $\varepsilon = Bvl$

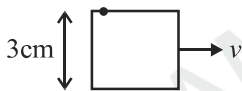

$$B = 0.3 \text{ T}$$

$$\varepsilon = 0.3 \times 0.03 \times 0.02$$

$$= 1.8 \times 10^{-4} \text{ volt.}$$

12. A galvanometer of resistance 100Ω gives full scale deflection for a current of 1 mA. It is converted into an ammeter of range $0-10 \text{ A}$. The shunt required is :

- (1) 0.01Ω (2) 0.10Ω
(3) 0.001Ω (4) 1.0Ω

Ans. 1

Sol. $G = 100 \Omega$ $I_g = 1 \text{ mA}$

$$I = 10 \text{ A}$$

$$S = \frac{I_g R_g}{I - I_g}$$

$$S = \frac{1 \times 10^{-3} \times 100}{10 - 0.001} \approx 0.01 \Omega$$

13. In Young's double slit experiment, using monochromatic light of wavelength λ , the intensity of light at a point on the screen where the path difference is λ is K units. The intensity of light at a point where the path difference is $\frac{\lambda}{3}$ will be :

- (1) $\frac{K}{4}$ (2) K
(3) $\frac{K}{2}$ (4) $2K$

Ans. 1

Sol. $I = K = 4I_0$

$$\Delta x = \frac{\lambda}{3} = \frac{\lambda}{2\pi} \cdot \Delta\phi \quad \Delta\phi = \frac{2\pi}{3}$$

$$I = 4I_0 \cos^2(\pi/3)$$

$$= 4I_0 \times \frac{1}{4} = \frac{K}{4}$$

14. The magnitude and direction of the acceleration produced in a body of mass 5 kg when two mutually perpendicular forces 8 N and 6 N act on it, are respectively :
- (1) 2 ms^{-2} ; $\tan^{-1}(3/4)$ with 6 N force
 - (2) 2 ms^{-2} ; $\tan^{-1}(4/3)$ with 8 N force
 - (3) 2 ms^{-2} ; $\tan^{-1}(3/4)$ with 8 N force
 - (4) 20 ms^{-2} $\tan^{-1}(4/3)$ with 8 N force

Ans. 3

Sol. $\tan \theta = \frac{3}{4}$

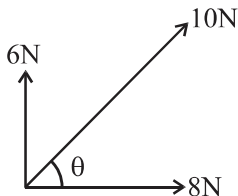

$$a = \frac{10}{5} = 2 \text{ m/s}^2$$

$$\tan^{-1}(3/4) \text{ with } 8\text{N}$$

15. Five capacitors of capacitances $C_1 = C_2 = C_3 = C_4 = 10 \mu\text{F}$ and $C_5 = 2.5 \mu\text{F}$ are connected as shown, along with a battery of 50 V.

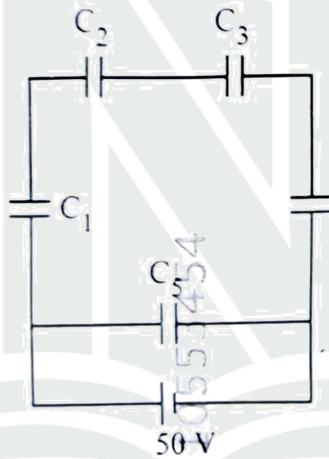

The equivalent capacitance and the charges on each capacitor respectively are :

- (1) $5 \mu\text{F}$, $125 \mu\text{C}$ on all capacitors
- (2) $5 \mu\text{F}$, $250 \mu\text{C}$ on all capacitors
- (3) $4 \mu\text{F}$, $250 \mu\text{C}$ on C_1 to C_4 and $125 \mu\text{C}$ on C_5
- (4) $5 \mu\text{F}$, $125 \mu\text{C}$ on C_1 to C_4 and $25 \mu\text{C}$ on C_5

Ans. 1

Sol.

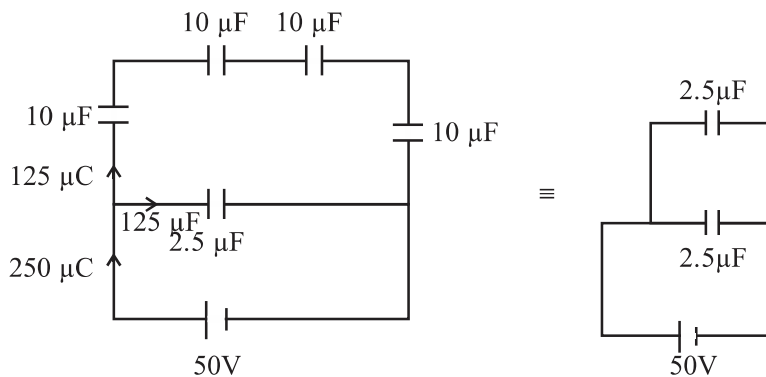

$$C_{eq} = 5 \mu\text{F}$$

$$Q = 50 \times 5 = 250 \mu\text{C}$$

Q on each capacitor $125 \mu\text{C}$

16. In a metre bridge experiment (see figure), the positions of the cell, E, and galvanometer, G, are interchanged. We shall observe in the galvanometer :

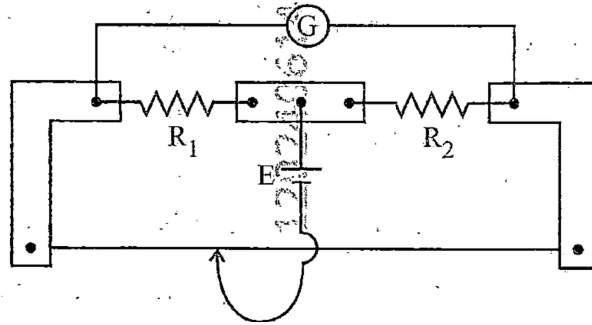

- (1) Only the right-sided deflection
- (2) Only the left-sided deflection
- (3) There will be no deflection irrespective of the position of the jockey
- (4) Both right-sided and left-sided deflection and at balance point, no deflection

Ans. 4

Sol. When the positions of the cell, E, and galvanometer, G, are interchanged null point remains same.

17. The power of a crane, which lifts a mass of 1000 kg to a height of 20 m in 10 s is :

$$(g = 9.8 \text{ m/s}^2)$$

- (1) 19.6 W
- (2) 39.2 W
- (3) 39.2 kW
- (4) 19.6 kW

Ans. 4

Sol. $w = mgh$
 $w = 1000 \times 9.8 \times 20$
 $p = \frac{1000 \times 9.8 \times 20}{10}$
 $= 19.6 \text{ kw}$

18. Match List I with List II:

	List I		List II
A.	Young's Modulus	I.	$\frac{\Delta d}{\Delta L} \left(\frac{L}{d} \right)$
B.	Compressibility	II.	$\frac{FL}{A(\Delta L)}$
C.	Bulk Modulus	III.	$-\frac{1}{\Delta P} \left(\frac{\Delta V}{V} \right)$
D.	Poisson's Ratio	IV.	$-P \left(\frac{V}{\Delta V} \right)$

Choose the correct answer from the options given below:

- (1) A-I, B-IV, C-III, D-II
- (2) A-IV, B-I, C-II, D-III
- (3) A-III, B-II, C-I, D-IV
- (4) A-II, B-III, C-IV, D-I

Ans. 4

Sol. $Y = \frac{F}{A\Delta L}$
 $B = \frac{-p}{(\Delta V/V)} = -p \left(\frac{V}{\Delta V} \right)$

$$C = \frac{1}{B}, \sigma = \frac{\Delta d}{\Delta L} \times \frac{L}{d}$$

19. In a concave lens, a ray of light emanating from the object parallel to the principal axis of the lens, after refraction :

- (1) emerges parallel to the principal axis.
- (2) appears to diverge from the first principal focus.
- (3) passes through $2F$, which is the radius of curvature of the lens.
- (4) passes through the second principal focus.

Ans. 2

Sol. Appears to diverge from the first Principal Focus.

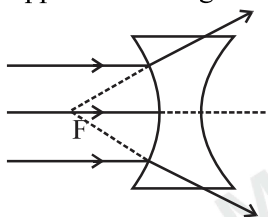

20. A thin wire of length 'L' and linear mass density 'm' is bent into a circular ring (in x-y plane) with centre 'C' as shown in figure. The moment of inertia of the ring about an axis yy' will be :

(1) $\frac{3mL^3}{8\pi^2}$

(2) $\frac{3mL^3}{8\pi}$

(3) $\frac{3mL^2}{8\pi^2}$

(4) $\frac{3mL^2}{8\pi}$

Ans. 1

Sol.

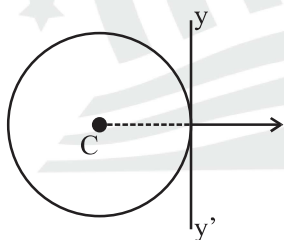

$$L = 2\pi r \quad (\lambda = m)$$

$$M_{\text{ass}} (M) = \lambda L = mL$$

$$I_{yy'} = \frac{1}{2} Mr^2 + Mr^2$$

$$= \frac{3}{2} Mr^2$$

$$= \frac{3}{2} (mL) \times \left(\frac{L}{2\pi} \right)^2$$

$$= \frac{3}{2} mL \times \frac{L^2}{4\pi^2}$$

$$\Rightarrow \left(\frac{3mL^3}{8\pi^2} \right)$$

21. Each side of a metallic cube of mass 5.580 kg is measured to be 9.0 cm. Keeping the significant figures in view, the density of the material of the cube can be best expressed as $X \times 10^3 \text{ kg m}^{-3}$, where the value of X is :

- (1) 7.654 (2) 7.7
(3) 7.65 (4) 7.6

Ans. 2

Sol. $M = 5.580 \text{ kg}$

$a = 9.0 \text{ cm}$

$$\rho = \frac{M}{\text{Volume}} = \frac{5.580}{9.0 \times 9.0 \times 9.0 \times 10^{-6}}$$

$$= 7.7 \times 10^3 [(7.654 \times 10^3)]$$

22. For a travelling harmonic wave $y(x, t) = 2.0 \cos 2\pi(10t - 0.0080x + 0.35)$, where x and y are in cm and t in s. The phase difference between oscillatory motion of two points separated by a distance of 0.5 m is :

- (1) $8\pi \text{ rad}$ (2) $0.08\pi \text{ rad}$
(3) $0.008\pi \text{ rad}$ (4) $0.8\pi \text{ rad}$

Ans. 4

Sol. $\Delta x = \frac{\lambda}{2\pi} \cdot \Delta \phi$

$$k = 2\pi \times 8 \times 10^{-3} \text{ cm}^{-1}$$

$$k = 2\pi \times 8 \times 10^{-3} \text{ cm}^{-1}$$

$$\lambda = \frac{2\pi}{k} = \frac{2\pi}{2\pi \times 8 \times 10^{-3} (\text{cm}^{-1})}$$

$$= \frac{10^3}{8} \text{ cm} \Rightarrow 1.25 \text{ m}$$

$$= \frac{10}{8} \text{ m} \Rightarrow (1.25)$$

$$0.5 = \frac{1.25}{2\pi} \times \Delta \phi$$

$$\Delta \phi = \frac{2\pi}{(2.5)} = (0.8\pi) \text{ rad.}$$

23. A ray of monochromatic light is passing through an equilateral prism (ABC) as shown in the figure. The refracted ray (QR) is parallel to its base (BC) and the angle of incidence (i) is 50° . Then the angle of deviation (δ) is :

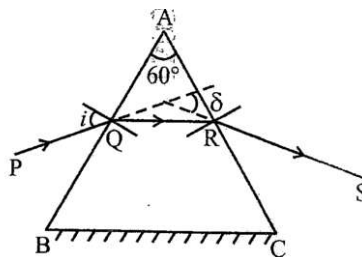

- (1) 40° (2) 45°
(3) 55° (4) 35°

Ans. 1

Sol. This is a case of minimum deviation

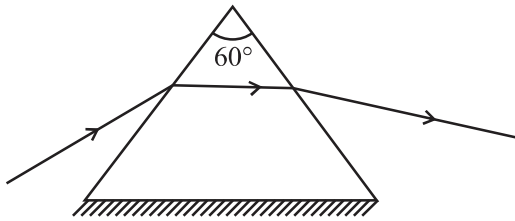

$$i = 50^\circ \quad A = 60^\circ$$

$$\delta_{\min} = i + e - A$$

$$= 2i - A$$

$$= 100 - 60$$

$$= 40^\circ$$

24. In the circuit shown below, the voltage appearing across the diode D will be of the form :

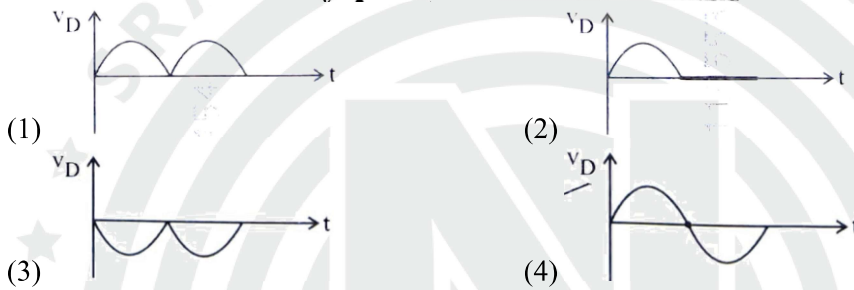
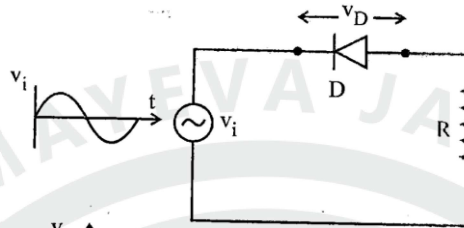

Ans. 2

Sol. First reverse bias.
then in forward bias.

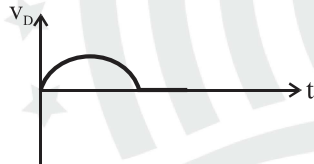

25. For a simple pendulum, having time period T, the variation of kinetic energy (K.E.) with time (t) is represented by :

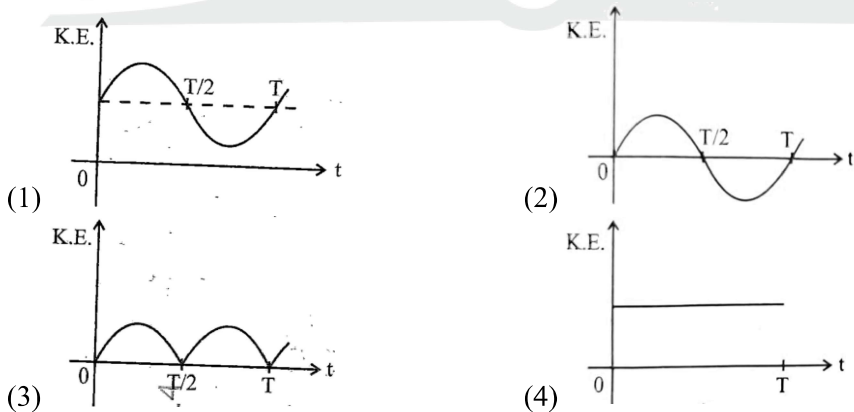

Ans. 3

Sol. $K.E. = \frac{1}{2} K A^2 \sin^2 \omega t$

By assuming particle starts from extreme.

26. A resistor is connected to a battery of 12 V emf and internal resistance 2Ω . If the current in the circuit is 0.6 A, the terminal voltage of the battery is :
- (1) 10 V (2) 10.8 V
(3) 12 V (4) 1.2 V

Ans. 2

Sol. $V = E - Ir$
 $= 12 - 2 \times 0.6 = 12 - 1.2 = 10.8V$

27. The amount of work done to raise a mass 'm' from the surface of the Earth to a height equal to radius of the Earth 'R', will be :
- (1) 2 mg R (2) mg R
(3) $mg \frac{R}{4}$ (4) $mg \frac{R}{2}$

Ans. 4

Sol. $\omega = \frac{mgR}{1 + \frac{R}{R}} = \frac{mgR}{2}$

28. An electric heater supplies heat to a system at rate of 100 W. If the system performs work at rate of 75 J/s, then the rate at which internal energy increases will be :
- (1) 125 W (2) 100 W
(3) 25 W (4) 75 W

Ans. 3

Sol. $\Delta\phi = \Delta u + w$
 $100 = \Delta u + 75$
 $\Delta u = 25 \text{ J/s}$

29. A room heater is rated 400 W, 200V. If the supply voltage drops to 220 V, what will be the power consumed (approximately) ?
- (1) 121 W (2) 331 W
(3) 200 W (4) 400 W

Ans. 2

Sol. $P = \frac{V^2}{R}$

$$\frac{P_1}{P_2} = \left(\frac{V_1}{V_2}\right)^2 \Rightarrow \frac{400}{P_2} = \left(\frac{220}{200}\right)^2$$

$$\frac{400}{P_2} = \frac{484}{400}$$

$$P_2 = \frac{400 \times 400}{484} \approx 330.57 \text{ W}$$

30. When a ruler falls vertically, 5 different persons catch it with different reaction times. ($g = 9.8 \text{ ms}^{-2}$)

- A. Person A has reaction time of 0.20 s.
 B. Person B has reaction time of 0.22 s.
 C. Person C has reaction time of 0.18 s.
 D. Person D has reaction time of 0.19 s.
 E. Person E has reaction time of 0.21 s.

What is the correct order of the distance travelled by the ruler for each person?

- (1) $C > D > A > B > E$
 (2) $C > D > A > E > B$
 (3) $B > E > A > C > D$
 (4) $B > E > A > D > C$

Ans. 4

Sol. $h = \frac{1}{2} g t^2$

$$h \propto t^2$$

$$h_B > h_E > h_A > h_D > h_C$$

31. Consider two uncharged capacitors of equal capacitance 200 pF. One of them is charged by a 100 V supply and disconnected. Now this capacitor is connected to the uncharged capacitor. The amount of electrostatic energy lost in the process is :

- (1) 1.0×10^{-6} J (2) 0.5×10^{-6} J
(3) 0.5 J (4) 1.0 J

Ans. 2

Sol. $\Delta u = \frac{1}{2} \frac{C_1 C_2}{C_1 + C_2} (V_1 - V_2)^2$

$$\frac{1}{2} \times \frac{200 \times 200 \times 10^{-24}}{400 \times 10^{-12}} \times 100 \times 100 = 0.5 \times 10^{-6} \text{ J}$$

32. Savitha, a XI standard student, while conducting an experiment to determine the effective length of a simple pendulum L, notes down the data of time taken to complete 30 oscillations as 60 s and hence calculates the length of the simple pendulum as :

(Take $\pi^2 = 9.8$, and $g = 9.8 \text{ m/s}^2$)

- (1) 2 m (2) 0.75 m
(3) 1.5 m (4) 1 m

Ans. 4

Sol. $T = 2\pi \sqrt{\frac{l}{g}}$

$$l = \frac{T^2}{4\pi^2} \times g$$

$$l = \frac{4}{4} = 1 \text{ m}$$

33. The peak value of an alternating current is 5 A and frequency is 60 Hz. How long will the current, starting from zero, take to reach the peak value?

- (1) $\frac{1}{240}$ s (2) $\frac{1}{30}$ s
(3) $\frac{1}{120}$ s (4) $\frac{1}{60}$ s

Ans. 1

Sol. $t = \frac{T}{4} = \frac{1}{4 \times 60} = \frac{1}{240} \text{ s}$

34. In interference and diffraction, the light energy is redistributed. If it reduces in one region, producing a dark fringe, it increases in another region, producing a bright fringe.

A. As there is no gain or loss of energy, these phenomena are consistent with the principle of conservation of energy.

B. Diffraction and interference are characteristics exhibited only by light waves.

Choose the correct answer from the options given below:

- (1) A is true, but B is false
(2) A is true and B is also true
(3) A is false, but B is true
(4) Both A and B are false

Ans. 1

Sol. Conceptual

35. A box of mass 15 kg is kept on the floor of a stationary trolley. The coefficient of static friction between the box and the trolley is 0.12. Keeping the box in stationary state over the trolley, the maximum acceleration with which the trolley can be moved horizontally in ms^{-2} is :

$$(g = 10 \text{ m/s}^2)$$

- (1) 1.5 (2) 1.8
(3) 2.1 (4) 1.2

Ans. 4

Sol. $\mu mg = ma$

$$a = \mu g$$

$$= 0.12 \times 10 = 1.2 \text{ m/s}^2$$

36. The sum of kinetic energy and potential energy of a simple pendulum bob is 0.02 joule. The speed of the simple pendulum bob at equilibrium position is approximately :

(Consider mass of the bob = 20 g)

- (1) 1.41 m/s (2) 14.1 m/s
(3) 0.2 m/s (4) 2.0 m/s

Ans. 1

Sol. $E = \frac{1}{2} m (\omega^2 A^2)$

$$\frac{2E}{m} = v_0^2$$

$$v_0^2 = \frac{2 \times 0.02}{20 \times 10^{-3}} = \frac{4 \times 10^{-2}}{20 \times 10^{-3}} = 2$$

$$v_0 = 1.41 \text{ m/s}$$

37. Four statements are given (A is mass number) :

A. The volume of a nucleus is proportional to $A^{1/3}$.

B. The volume of a nucleus is proportional to A.

C. The difference in mass of an atom and its nucleus is called the mass defect.

D. The difference in mass of a nucleus and its constituents is called the mass defect.

Choose the correct answer from the options given below :

- (1) B and D are true, but A and C are false
(2) A and D are true, but B and C are false
(3) A and C are true, but B and D are false
(4) B and C are true, but A and D are false

Ans. (1)

Sol. B, D True,

38. The angular speed of a flywheel is increased from 600 rpm to 1200 rpm in 10 s. The number of revolutions completed by the flywheel during this time is :

- (1) 600 (2) 900
(3) 300 (4) 150

Ans. (4)

Sol. $\left(\frac{\omega_1 + \omega_2}{2} \times t \right) \frac{1}{2\pi} = 150$

39. A submarine is designed to withstand an absolute pressure of 100 atm. How deep can it go below the water surface ?

(Consider the density-of water = 1000 kg m^{-3} , $1 \text{ atm} = 1 \times 10^5 \text{ Pa}$ and gravitational acceleration $g = 10 \text{ m/s}^2$)

- (1) 9900 m (2) 99 m
(3) 9000 m (4) 990 m

Ans. (4)

Sol. $\Delta p = \rho gh$

$$99 \times 10^5 = 1000 \times 10 \times h$$

$$h = 990 \text{ m}$$

40. Match List I with List II:

	List I (Electromagnetic wave)		List II (Production)
A.	Microwave	I.	Electrons in atoms emit light when they move from a higher energy level to a lower energy level
B.	Visible light	II.	Radioactive decay of nucleus
C.	Gamma rays	III.	Vibration of atoms and molecules
D.	Infra-red rays	IV.	Klystron valve or magnetron valve

Choose the correct answer from the options given below:

(1) A-III, B-I, C-II, D-IV

(2) A-III, B-IV, C-I, D-II

(3) A-IV, B-III, C-II, D-I

(4) A-IV, B-I, C-II, D-III

Ans. (4)

Sol. $A \rightarrow IV, B \rightarrow I, C \rightarrow II$

41. Which of the following statements are correct?

A. Inside a conductor, the electrostatic field is zero.

B. Electric field at the surface of a charged conductor does not depend on its surface charge density.

C. The interior of a charged conductor can have no excess charge in the static situation.

D. At the surface of a charged conductor, the electrostatic field must be normal to the surface at every point.

E. The electrostatic potential is zero everywhere inside a charged conductor.

Choose the correct answer from the options given below:

(1) C, D and E only

(2) A, B and D only

(3) A, C and D only

(4) A, C and E only

Ans. (3)

Sol. Conceptual

42. For a metal of work function 6.6 eV, which of the following wavelengths of incident radiation does not give rise to the photoelectric effect?

(Take Planck's constant as $6.6 \times 10^{-34} \text{ Js}$)

(1) 200 nm

(2) 150 nm

(3) 100 nm

(4) 50 nm

Ans. (1)

Sol. $\phi = 6.6$

$$\lambda_0 = \frac{1240}{6.6} = 187.8 \text{ nm}$$

for $E > \phi$ only e^- emission

43. In the first excited state of hydrogen atom, the energy of its electron is -3.4 eV. The radial distance of the electron from the hydrogen nucleus in this case is approximately :

(Take $1 \text{ eV} = 1.6 \times 10^{-19} \text{ J}$, $e = 1.6 \times 10^{-19} \text{ C}$ and $\frac{1}{4\pi\epsilon_0} = 9 \times 10^9 \text{ Nm}^2 / \text{C}^2$)

(1) $2.1 \times 10^{-8} \text{ m}$

(2) $2.1 \times 10^{-11} \text{ m}$

(3) $2.1 \times 10^{-9} \text{ m}$

(4) $2.1 \times 10^{-10} \text{ m}$

Ans. (4)

Sol. $r = 0.53 \times \frac{n^2}{Z} = 0.53 \times 4 = 2.12 \times 10^{-10} \text{ m}$

44. Two statements are given below:
 A. When the forward bias voltage across a p-n junction diode increases above a certain threshold voltage, the diode current increases significantly.
 B. This current is called reverse saturation current.
 Choose the correct answer from the options given below:
 (1) Both Statements A and B are false
 (2) Statement A is true, but Statement B is false
 (3) Both Statements A and B are true
 (4) Statement A is false, but Statement B is true

Ans. 2

Sol.

45. A flask contains argon and chlorine in the ratio of 2 : 1 by mass. The temperature of the mixture is 27°C . The ratio of root mean square speed of the molecules of the two gases $\left(\frac{v_{\text{rms}}^{\text{Ar}}}{v_{\text{rms}}^{\text{Cl}}}\right)$ is :

(Atomic mass of argon = 40.0u and molecular mass of chlorine = 70.0u)

- (1) $\frac{\sqrt{7}}{2}$ (2) $\frac{7}{2}$
 (3) $\frac{7}{4}$ (4) $\frac{2}{\sqrt{7}}$

Ans. 1

Sol.

$$v = \sqrt{\frac{3RT}{m}}$$

$$\frac{v_1}{v_2} = \sqrt{\frac{m_2}{m_1}} = \sqrt{\frac{70}{40}} = \frac{\sqrt{7}}{2}$$

CHEMISTRY

46. Match List-I with List II:

List-I

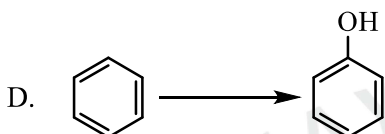
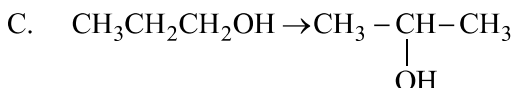
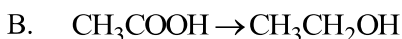
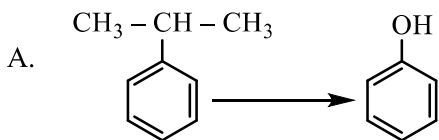

List-II

I. (i) oleum; (ii) NaOH; (iii) H^+

II. (i) O_2 ; (ii) $\text{H}_2\text{O}/\text{H}^+$

III. (i) $\text{CH}_3\text{OH}, \text{H}^+$; (ii) H_2 , catalyst

IV. (i) conc. $\text{H}_2\text{SO}_4, \Delta$; (ii) $\text{H}^+ / \text{H}_2\text{O}$

Choose the correct answer from the options given below:

(1) A-I, B-III, C-IV, D-II

(2) A-II, B-IV, C-III, D-I

(3) A-II, B-III, C-I, D-IV

(4) A-II, B-III, C-IV, D-I

Ans. 4

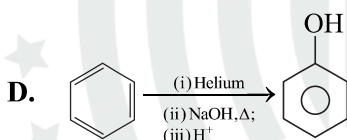
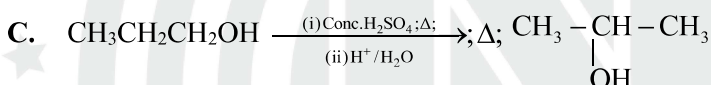
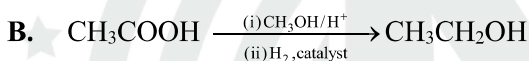
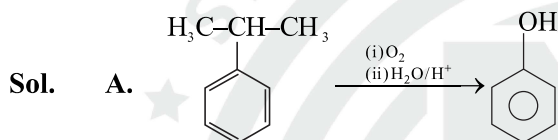

47. The major product z formed in the following sequence of reactions is :



(1) $\text{C}_2\text{H}_5 - \text{N} = \text{N} - \text{OH}$

(2) $\text{C}_2\text{H}_5\text{OH}$

(3) $\text{C}_2\text{H}_5\text{NO}_2$

(4) $\text{C}_2\text{H}_5\text{NH}_2$

Ans. 2

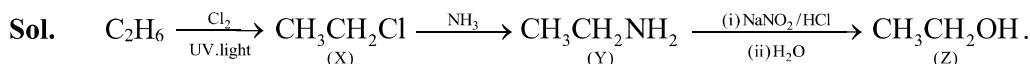

48. In a qualitative analysis Bi^{3+} is detected by appearance of precipitate of $\text{BiO}(\text{OH})(\text{s})$. Calculate pH when the following equilibrium exists at 298 K:

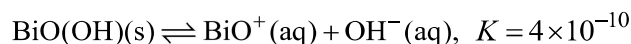

(Given : $\log 2 = 0.3010$)

(1) 4.699

(2) 8.714

(3) 9.301

(4) 5.286

Ans. 3

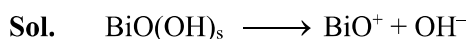

$$k = (\text{BiO}^+) (\text{OH}^-)$$

$$4 \times 10^{-10} = x \cdot x = x^2$$

$$(\text{OH}^-) = 2 \times 10^{-5}$$

$$\text{pOH} = -\log 2 \times 10^{-5} = s - 0.3010$$

$$\text{pH} = 14 - 4.69 = 9.3010$$

49. When 1 dm³ of CO₂ gas is passed over hot coke, the volume of gaseous mixture after complete reaction at STP becomes 1.4 dm³. The composition of the gaseous mixture at STP is:

- (1) 0.6 dm³ of CO, 0.8 dm³ of CO₂ (2) 0.8 dm³ of CO, 0.8 dm³ of CO₂
 (3) 0.8 dm³ of CO, 0.6 dm³ of CO₂ (4) 0.6 dm³ of CO, 0.4 dm³ of CO₂

Ans. 3

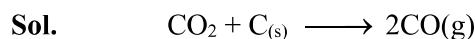

Initial $\rightarrow 1\text{dm}^3$

Final $\rightarrow 1-x \longrightarrow 2x$

Given: $1-x + 2x = 1.4$

Hence $\text{CO} = 2x = 2 \times 0.4 = 0.8$

$\text{CO}_2 = 1-x = 1-0.4 = 0.6$

50. Match List-I with List II:

List-I (Quantum Number)

List-II (Orbital)

	'n'	'l'
A.	2	1
B.	4	0
C.	5	3
D.	3	2

- I. 3d
 II. 2p
 III. 4s
 IV. 5f

Choose the correct answer from the options given below:

- (1) A-II, B-III, C-IV, D-I (2) A-I, B-II, C-III, D-IV
 (3) A-IV, B-II, C-III, D-I (4) A-II, B-III, C-I, D-IV

Ans. 1

Sol.

	'n'	'l'
A.	2	1
B.	4	0
C.	5	3
D.	3	2

- I. 2p
 II. 4s
 III. 5f
 IV. 3d

51. The number of chlorine atoms present in the organic products X and Y of the following reactions, respectively, are

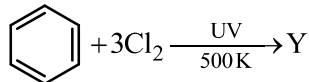
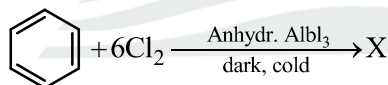

- (1) 3 and 6 (2) 6 and 6
 (3) 6 and 3 (4) 3 and 3

Ans. 2

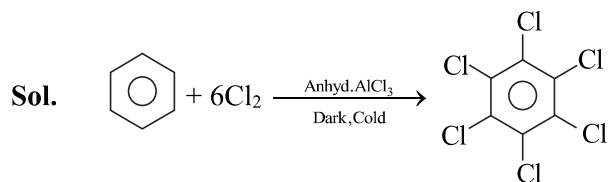

Hexachlorbenzene

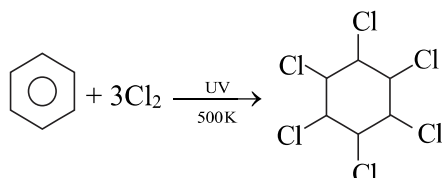

Benzene hexachlorine

52. In the following reaction sequence, X and Z, respectively are :

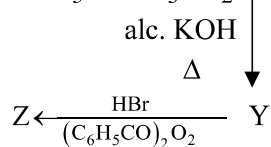
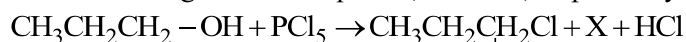

- (1) $\text{X} = \text{POCl}_3$; $\text{Z} = \text{CH}_3-\underset{\text{Br}}{\text{CH}}-\text{CH}_3$ (2) $\text{X} = \text{H}_3\text{PO}_3$; $\text{Z} = \text{CH}_3\text{CH}_2\text{CH}_2-\text{Br}$
 (3) $\text{X} = \text{H}_3\text{PO}_3$; $\text{Z} = \text{CH}_3-\underset{\text{Br}}{\text{CH}}-\text{CH}_3$ (4) $\text{X} = \text{POCl}_3$; $\text{Z} = \text{CH}_3\text{CH}_2\text{CH}_2-\text{Br}$

Ans. 4

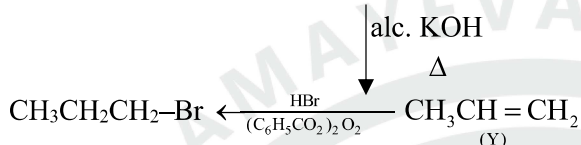
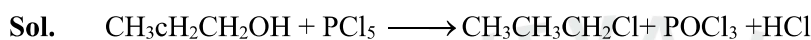

53. Match List-I with List II:

List-I
(transition metal/
compound/complex)

- A. V_2O_5
B. Fe
C. PdCl_2
D. Ni complex

List-II
(Catalytic Role)

- I. Preparation of ammonia from N_2 / H_2 mixture
II. Polymerisation of alkynes
III. Preparation of H_2SO_4 from SO_2
IV. Oxidation of ethyne to ethanal

Choose the correct answer from the options given below:

- (1) A-III, B-IV, C-I, D-II (2) A-II, B-I, C-IV, D-III
(3) A-IV, B-I, C-III, D-II (4) A-III; B-I, C-IV, D-II

Ans. 4

Sol. Fact

54. Identify the correct statement about ClF_3 from the following options :

- (1) It has a trigonal pyramidal geometry with two lone pairs on Cl atom.
(2) It has T-shaped geometry with two lone pairs on Cl atom. -
(3) It has a planar trigonal geometry with two lone pairs on Cl atom.
(4) It has T-shaped geometry with three lone pairs on Cl atom.

Ans. 2

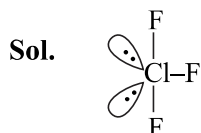

T shaped geometry
with two lone pairs on Cl atom.

55. Calculate emf of the half-cell given below:

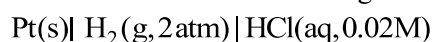

$$E_{\text{H}_2/\text{H}^+}^0 = 0 \text{ V}$$

(Given: $\frac{2 \cdot 303RT}{F} = 0.059$, $\log 2 = 0.3010$)

- (1) 1.109 V (2) 0.035 V
(3) -0.035 V (4) -0.109 V

Ans. 1

Sol.
$$E_{\text{H}_2/\text{H}^+} = E_{\text{H}_2/\text{H}^+}^0 - \frac{2.305RT}{nF} \log \frac{[\text{H}^+]}{[\text{P}_{\text{H}_2}]}$$
$$= 0 - \frac{.059}{2} \log \frac{(0.02)^2}{2}$$
$$= -\frac{.059}{2} \log 2 \times 10^{-4} = 0.109 \text{ V}$$

56. Match List-I with List II:

List-I (Order of reaction)

- A. Zero order
- B. First order
- C. Second order
- D. Third order

List-II (Unit of rate constant)

- I. $\text{mol}^{-1} \text{L s}^{-1}$
- II. $\text{mol}^{-2} \text{L}^2 \text{s}^{-1}$
- III. s^{-1}
- IV. $\text{mol}^{-1} \text{L}^{-1} \text{s}^{-1}$

Choose the correct answer from the options given below:

- (1) A-IV, B-III, C-II, D-I
- (2) A-I, B-II, C-III, D-IV
- (3) A-IV, B-III, C-I, D-II
- (4) A-IV, B-II, C-I, D-III.

Ans. 3

Sol. Unit = $(\text{mol L}^{-1})^{1-n} \text{s}^{-1}$
n = order of reaction

57. The calculated 'spin-only' magnetic moment of $\text{Ti}^{2+} (3d^2)$ is :

- (1) 2.84 BM
- (2) 5.92 BM
- (3) 4.90 BM
- (4) 3.87 BM

Ans. 1

Sol. $\text{Ti}^{+2} = {}_{18}[\text{Ar}]4s^0 3d^2$
n = 2
$$\mu = \sqrt{n(n+2)} = \sqrt{2(2+2)} = \sqrt{8} = 2.84 \text{ BM}$$

58. Two products X and Y are formed in the following reaction sequence.

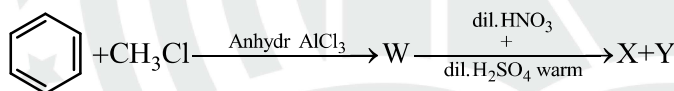

The suitable method that can be used for the separation of products X and Y is:

- (1) Continuous extraction
- (2) Differential extraction
- (3) Fractional distillation
- (4) Sublimation

Ans. 3

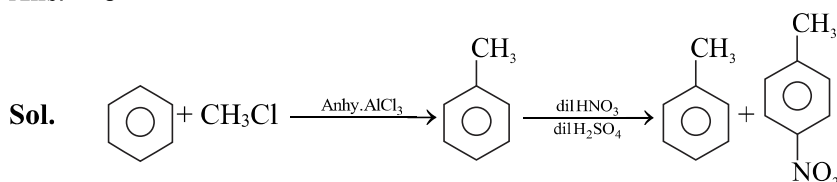

X and Y have BP close to each other so it separated by fractional distillation.

59. A bulb is rated at 150 watt, converting 8% energy into light. If energy of one photon is $4.42 \times 10^{-19} \text{ J}$, how many photons are emitted by the bulb per second?

- (1) 1.35×10^{19}
- (2) 4.06×10^{19}
- (3) 2.71×10^{19}
- (4) 27.2×10^{19}

Ans. 3

Sol. No. of photon = ?
Light energy = 8% of 150 W rated bulb
$$= \frac{150 \times 8}{100} = 12 \text{ J / sec}$$

Sol. Mole of urea = $\frac{5.4}{60} = 0.09$

Number of total H-atom = $0.09 \times 6.022 \times 10^{23} \times 4 = 2.168 \times 10^{23}$

66. The pair of molecules that are metamers among the following is:

(1) $\text{CH}_3\text{CH}_2\text{CH}_2\text{OH}$ and $\text{CH}_3 - \text{CH}(\text{OH}) - \text{CH}_3$

(2) $\text{CH}_3\text{OCH}_2\text{CH}_2\text{CH}_3$ and $\text{CH}_3\text{CH}_2\text{OCH}_2\text{CH}_3$

(3) $\text{H}_3\text{C} - \overset{\text{O}}{\parallel} \text{C} - \text{CH}_3$ and $\text{H}_3\text{C} - \text{CH}_2 - \overset{\text{O}}{\parallel} \text{C} - \text{H}$

(4) $\text{CH}_3\text{CH}_2\text{CH}_2\text{CH}_2\text{CH}_3$ and $(\text{CH}_3)_2\text{CHCH}_2\text{CH}_3$

Ans. (2)

Sol. alkyl group on both side of ether is different.

67. Identify the incorrect statement from the following:

(1) $\text{P}(\text{C}_2\text{H}_5)_3$ and $\text{As}(\text{C}_6\text{H}_5)_3$ form $d\pi - d\pi$ bond with transition metals.

(2) Nitrogen can form $d\pi - p\pi$ bond with oxygen.

(3) Nitrogen can form $p\pi - p\pi$ multiple bonds with itself.

(4) Phosphorus, arsenic and antimony show catenation property.

Ans. (2)

Sol. Nitrogen can't form $d\pi - p\pi$ bond with oxygen as both N and O does not have d-orbital.

68. Phenolphthalein is used as an indicator for the titration of sodium hydroxide solution against a standard solution of oxalic acid. The colour change that is observed at an alkaline pH close to the equivalence point during this titration is:

(1) pinkish red to yellow

(2) yellow to pinkish red

(3) colourless to pink

(4) pink to colourless

Ans. (3)

Sol. Colorless to pink

$\text{HPh} \rightleftharpoons \text{H}^+ + \underset{\text{Pink}}{\text{Ph}^-}$ (favoured in basic (weak medium))

69. Match List I with List II :

List-I

A. C_2H_4

B. C_2H_2

C. CH_4

D. NH_3

List-II

I. 3σ bond, 2π bonds

II. 3σ bond, one lone pair

III. 4σ bond

IV. 5σ bond, 1π bond

Choose the correct answer from the options given below:

(1) A-IV, B-I, C-III, D-II

(2) A-III, B-IV, C-II, D-I

(3) A-I, B-II, C-IV, D-III

(4) A-II, B-III, C-I, D-IV

Ans. (1)

Sol. I. $\begin{array}{c} \text{H} & & \text{H} \\ & \diagdown & / \\ & \text{C} = \text{C} & \\ & / & \diagdown \\ \text{H} & & \text{H} \end{array} \rightarrow 5\sigma + 1\pi$

II. $\text{H} - \text{C} \equiv \text{C} - \text{H} \rightarrow 3\sigma + 2\pi$

III. $\text{CH}_4 \rightarrow 4\sigma$ bond

IV. $\text{NH}_3 \rightarrow 3\sigma$ bond, 1 lone pair.

70. At a certain temperature, T(K), during a process, 500 J is absorbed by the system and work of 200 J is done by the system. Then change in internal energy of the system is:

(1) 700 J

(2) 300 J

(3) 400 J

(4) 500 J

Ans. (2)

Sol. $\Delta U = q + W$

$= 500 + (-200) = 300 \text{ J}$

71. Methane reacts with steam at 1273 K in the presence of nickel catalyst to form:

- (1) CO and H₂ (2) CO and H₂O
 (3) CO₂ and H₂O (4) CO₂ and H₂

Ans. (1)

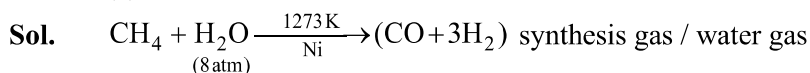

72. Compound P(C₈H₈O) gives a red orange precipitate with 2,4-DNP reagent and it does not reduce Fehling's reagent. On drastic oxidation with chromic acid, P gives an aromatic product Q that produces effervescence on treating with aq. NaHCO₃. Compounds P and Q, respectively, are:

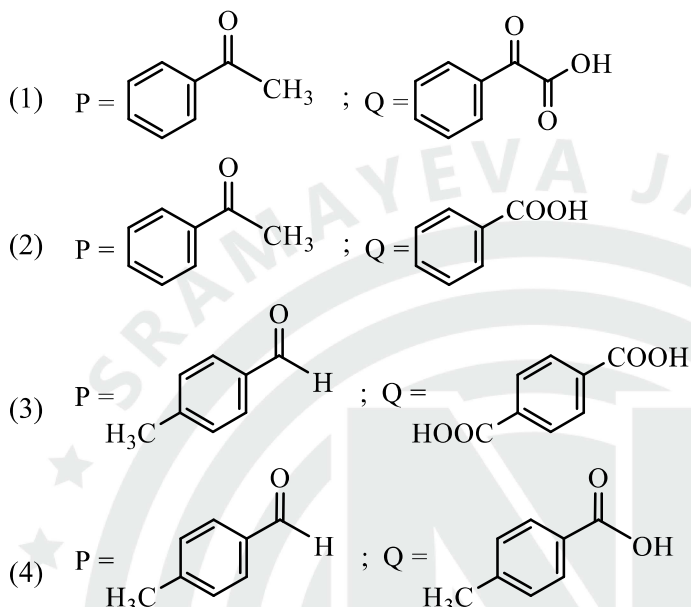

Ans. (1)

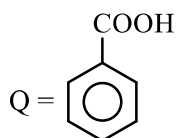
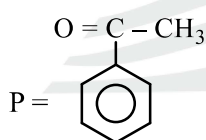
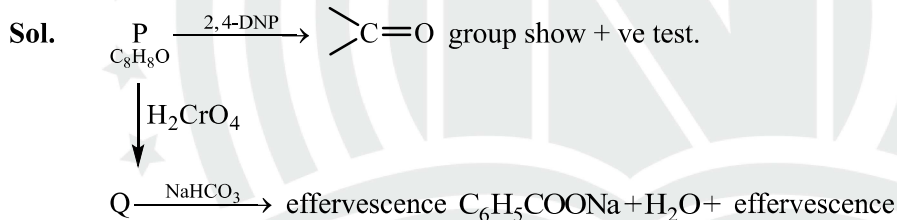

73. A solution of copper sulphate is electrolysed for 10 minutes with a current of 1.5 amperes. The mass of copper deposited at cathode is:

(Given: Molar mass of Cu = 63 g mol⁻¹; 1 F = 96487 C mol⁻¹).

- (1) 2.4036 g (2) 1.7018 g
 (3) 0.5876 g (4) 0.2938 g

Ans. (4)

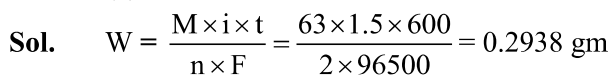

74. The functional group that can be identified through phthalein dye test is:

- (1) Phenolic (2) Alcohol
 (3) Aldehyde (4) Carboxylic acid

Ans. (1)

Sol. Phenol + Phthalic anhydride

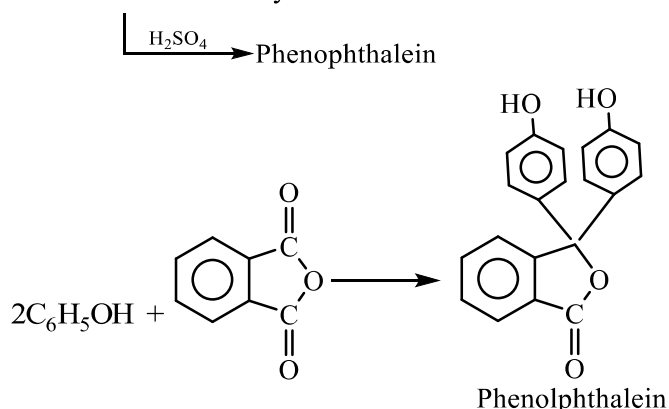

75. The correct statement with regard to the secondary structure of DNA/RNA is:

- (1) DNA possesses a single strand helix structure and contains uracil as one of the four bases.
- (2) RNA possesses a single strand helix structure and contains thymine as one of the four bases.
- (3) DNA possesses a double strand helix structure and contains thymine as one of the four bases.
- (4) RNA possesses a double strand helix structure and contains uracil as one of the four bases.

Ans. (3)

Sol. DNA – Double stand helix structure.

76. Identify the correct statements:

- A. The molality of 2.5g of ethanoic acid (Molar mass 60 g mol^{-1}) in 75g of benzene solution is 0.556 m.
- B. The molarity of a solution containing 5g of NaOH (molar mass: 40 g mol^{-1}) in 450 mL of solution is 0.278 M at 298 K.
- C. Aquatic species are more comfortable in cold water.
- D. The solubility of gas increases with decrease in pressure.
- E. For a binary mixture of A and B, the number of moles of A and B are n_A and n_B respectively.

The mole fraction of B will be $x_B = \frac{n_B}{n_A + n_B}$.

Choose the correct answer from the options given below:

- (1) A and C only
- (2) A, B and C only
- (3) A, D and E only
- (4) A and B only

Ans. (2)

Sol. (C) → Due to more oxygen content

77. Mixture of chloroform and acetone forms a solution with negative deviation from Raoult's law due to:

- (1) formation of hydrogen bonding between acetone and chloroform.
- (2) increase in escaping tendency of molecules of each component.
- (3) stronger intermolecular forces between chloroform molecules than those between chloroform and acetone molecules.
- (4) repulsive forces.

Ans. (1)

Sol. Formation of hydrogen bonding between acetone and chloroform.

78. At 298 K, a certain buffer solution contains equal concentrations of X^- and HX, K_b for X is 10^{-10} . What is the pH of this buffer solution?

- (1) 2
- (2) 10
- (3) 4
- (4) 6

Ans. (3)

Sol. $K_a = \frac{K_w}{K_b} = \frac{10^{-14}}{10^{-10}} = 10^{-4}$

$$\text{Now, } \text{pH} = \text{pK}_a + \log \frac{[\text{salt}]}{[\text{acid}]}$$

$$\text{Since } [\text{X}^-] = [\text{HX}]$$

$$= 4 + \log \frac{\text{X}^-}{\text{HX}} = 4$$

79. Identify the incorrect statement from the following:

- (1) The IUPAC name of the element with atomic number 107 is Unnilseptium.
- (2) The largest and the smallest species among Mg, Mg^{2+} , Al and Al^{3+} are Al and Mg^{2+} , respectively.
- (3) The similarity in behaviour of Li with Mg is referred to as 'diagonal relationship'.
- (4) The oxidation state and covalency of Al in $[\text{AlCl}(\text{H}_2\text{O})_5]^{2+}$ are 3 and 6 respectively.

Ans. 2

Sol. Fact

80. The correct order of increasing metallic character of Na, Be, P, Mg and Si is :

- (1) $\text{P} < \text{Si} < \text{Be} < \text{Mg} < \text{Na}$
- (2) $\text{Be} < \text{Si} < \text{P} < \text{Mg} < \text{Na}$
- (3) $\text{P} < \text{Si} < \text{Na} < \text{Mg} < \text{Be}$
- (4) $\text{P} < \text{Mg} < \text{Be} < \text{Si} < \text{Na}$

Ans. 1

Sol. Fact

81. The correct IUPAC name of the following compound is:

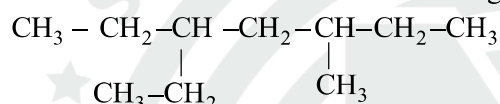

- (1) 2,4-diethylhexane
- (2) 3,5-diethylhexane
- (3) 3-ethyl-5-methylheptane
- (4) 3-methyl-5-ethylheptane

Ans. 3

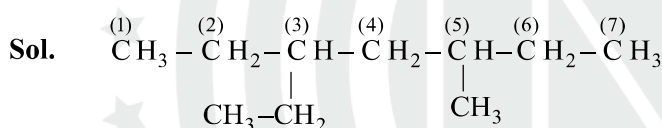

82. Match List I with List II:

List-I (Complex / ion)

- A. $[\text{Pt}(\text{Cl}_2)(\text{NH}_3)_2]$
- B. $[\text{Co}(\text{NH}_3)_6]\text{Cl}_3$
- C. $[\text{NiCl}_4]^{2-}$
- D. $[\text{Fe}(\text{CO})_5]$

List-II (Shape / geometry)

- I. Octahedral
- II. Trigonal bipyramidal
- III. Square planar
- IV. Tetrahedral

Choose the correct answer from the options given below:

- (1) A-I, B-III, C-IV, D-II
- (2) A-III, B-IV, C-I, D-II
- (3) A-IV, B-I, C-III, D-II
- (4) A-III, B-I, C-IV, D-II

Ans. 4

Sol. Fact

83. For a certain reaction $\text{R} \rightarrow \text{Product}$, the plot of concentration $[\text{R}]$ vs time has a negative slope as shown. The order of reaction is:

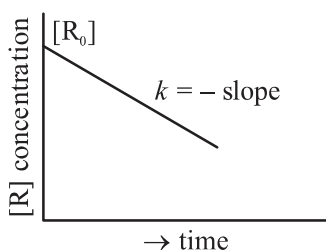

- (1) 0
- (2) 1
- (3) 2
- (4) 2.5

Ans. 1

Sol. It is type of zero order reaction

84. Which one of the following is an ambidentate ligand ?

- (1) Ethylenediaminetetraacetate ion (2) Oxalate
(3) Ethane-1,2-diamine (4) Thiocyanate

Ans. 4

Sol. Fact

85. Consider the following reaction :

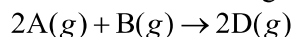

$$\Delta U^\ominus = -10\text{kJ mol}^{-1} \text{ and } \Delta S^\ominus = -44\text{JK}^{-1} \text{ at } 298 \text{ K.}$$

Identify the correct option with ΔG^\ominus for the reaction and spontaneity of the reaction at 298 K.

(Given : $R = 8.31\text{J mol}^{-1} \text{K}^{-1}$)

- (1) -1.635kJ mol^{-1} , spontaneous (2) $+0.63568\text{kJ mol}^{-1}$, non-spontaneous
(3) $-0.63568\text{kJ mol}^{-1}$, spontaneous (4) $+1.635\text{kJ mol}^{-1}$, non-spontaneous

Ans. 2

Sol.

$$\begin{aligned} \Delta H &= \Delta U + nRT \\ &= -10000 - 8.31 \times 298 \\ &= -12476.3 \text{ J} \\ \Delta G &= \Delta H - T\Delta S \\ &= 1247.3 \text{ J} - (-44 \times 298) \\ &= -12476.3 \text{ J} + 13111.98 = 635.68 \\ &= +.63568 \text{ kJ/mol} \end{aligned}$$

86.

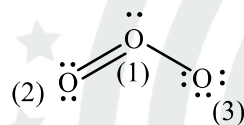

The correct formal charges on oxygen atoms numbered 2, 1 and 3 respectively are:

- (1) $-1, 0, +1$ (2) $0, +1, -1$
(3) $0, 0, 0$ (4) $+1, 0, -1$

Ans. 2

Sol.

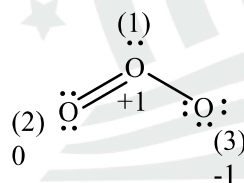

87.

Given below are certain reactions. Identify the reaction for which $K_p \neq K_c$.

- (1) $\text{H}_2(\text{g}) + \text{I}_2(\text{g}) \rightleftharpoons 2\text{HI}(\text{g})$ (2) $\text{N}_2(\text{g}) + \text{O}_2(\text{g}) \rightleftharpoons 2\text{NO}(\text{g})$
(3) $\text{N}_2(\text{g}) + 3\text{H}_2(\text{g}) \rightleftharpoons 2\text{NH}_3(\text{g})$ (4) $\text{H}_2\text{O}(\text{g}) + \text{CO}(\text{g}) \rightleftharpoons \text{H}_2(\text{g}) + \text{CO}_2(\text{g})$

Ans. 3

Sol. In IIIrd options $\Delta n_g < 1$ and in rest all $\Delta n_g = 0$.

88. Given below is an expression for the rate constant of a first order reaction occurring at a certain temperature, T(K).

$$\ln k = 14.34 - \frac{1.25 \times 10^4}{T}$$

The energy of activation in kcal mol^{-1} for the reaction is:

(Given: k in s^{-1} , $R = 1.987\text{cal mol}^{-1} \cdot \text{K}^{-1}$)

- (1) 12.42 (2) 14.34
(3) 18.63 (4) 24.84

Ans. 4

Sol. $\ln K = 14.34 - \frac{1.25 \times 10^4}{T}$

$$\ln K = \ln A - \frac{E_a}{RT}$$

$$\frac{E_a}{RT} = \frac{1.25 \times 10^4}{T} = E_a = R \times 1.25 \times 10^4$$

$$= 1.9 \times 1.25 \times 10^4$$

$$= 24.84$$

89. The following two reactions give the same foul smelling product Z.

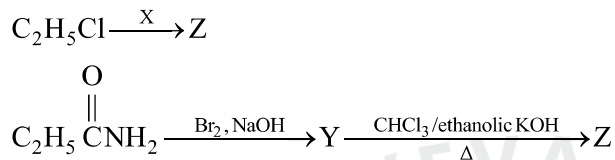

X and Z, respectively, are :

- (1) X = AgCN; Z = C₂H₅CN (2) X = KCN; Z = C₂H₅CN
 (3) X = KCN; Z = C₂H₅NC (4) X = AgCN; Z = C₂H₅NC

Ans. 4

Sol. X = AgCN

Z = C₂H₅NC

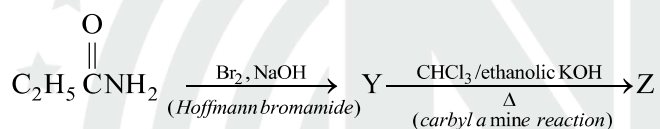
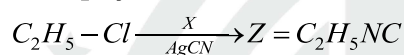

Y = C₂H₅-NH₂

Z = C₂H₅NC

90. Match List I with List II:

List-I (Complex)

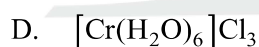

List-II (Type of isomerism)

I. Optical

II. Solvate

III. Geometrical

IV. Linkage

Choose the correct answer from the options given below:

(1) A-III, B-I, C-II, D-IV

(2) A-I, B-III, C-II, D-IV

(3) A-III, B-I, C-IV, D-II

(4) A-II, B-IV, C-III, D-I

Ans. 3

Sol. According to isomerism

BIOLOGY

91. "The Evil Quartet" of biodiversity loss includes which of the following?
- (1) Over-exploitation; Alien species invasions; Air pollution; Co-extinctions
 - (2) Habitat loss and fragmentation; over-exploitation; Alien species invasions; Co-extinctions
 - (3) Habitat loss and fragmentation; Air pollution; Water pollution; Co-extinctions
 - (4) Over-exploitation; Alien species invasions; Soil pollution; Co-extinctions

Ans. 2

92. Which one of the following is the site for active ribosomal RNA synthesis?
- (1) Nucleolus
 - (2) Chromatin
 - (3) Centrosome
 - (4) Kinetochore

Ans. 1

93. Match List I with List II:

List I

(Phase of cell cycle)

- A. G₁ phase
- B. S phase
- C. G₂ phase
- D. M phase

List II

(Activity)

- I. Actual cell division occurs
- II. Cell is metabolically active and continuously grows but does not replicate its DNA
- III. Synthesis of DNA occurs and the amount of DNA per cell doubles
- IV. Proteins are synthesized while cell growth continues

Choose the correct answer from the options given below:

- (1) A-II, B-III, C-IV, D-I
- (2) A-III, B-IV, C-I, D-II
- (3) A-I, B-II, C-III, D-IV
- (4) A-IV, B-I, C-II, D-III

Ans. 1

94. Match List I with List II:

List I

- A. Productivity
- B. Net primary productivity
- C. Gross primary productivity
- D. Secondary productivity

List II

- I. Gross primary productivity minus respiration losses
- II. Rate of formation of new organic matter by consumers
- III. Rate of biomass production
- IV. Rate of production of organic matter during photosynthesis

Choose the correct answer from the options given below:

- (1) A-I, B-II, C-III, D-IV
- (2) A-III, B-I, C-IV, D-II
- (3) A-III, B-I, C-II, D-IV
- (4) A-I, B-III, C-IV, D-II

Ans. 2

95. Which of the following statements are correct?
- A. The Amazon rainforest being cut and cleared for cultivation of soyabeans is an example of habitat loss.
 - B. Steller's sea cow and passenger pigeon became extinct due to over-exploitation by humans.
 - C. The Nile perch introduced into Lake Victoria in East Africa helped in population growth of cichlid fish in the lake.
 - D. Water hyacinth is an invasive species.
 - E. When a species becomes extinct, the plant and animal species associated with it are not affected.

Choose the correct answer from the options given below:

- (1) B, C and D only
- (2) A, B and D only
- (3) A, B and E only
- (4) C, D and E only

Ans. 2

96. Identify the correct statements about biomolecules.

- A. Lipids are generally water soluble.
- B. Proteins are polypeptides.
- C. Polysaccharides are long chains of sugars.
- D. Adenine and guanine are substituted pyrimidines.
- E. Almost all enzymes are proteins.

Choose the correct answer from the options given below:

- (1) C, D and E only
- (2) B, C and E only
- (3) B, D and E only
- (4) A, B and C only

Ans. 2

97. How many ATP and NADPH molecules are required to make one molecule of glucose through the Calvin pathway?

- (1) 18 ATP and 12 NADPH
- (2) 6 ATP and 12 NADPH
- (3) 24 ATP and 18 NADPH
- (4) 12 ATP and 18 NADPH

Ans. 1

98. Which of the following statements are not true regarding restriction endonucleases?

- A. They are called molecular scissors.
- B. These are the enzymes responsible for restricting the growth of bacteriophages in *E. coli*.
- C. They cut the DNA only at the centre of the palindromic sites.
- D. They remove nucleotides only from the ends of DNA fragments.
- E. They recognise specific palindromic base-pair sequences.

Choose the answer from the options given below:

- (1) A and B only
- (2) D and E only
- (3) C and D only
- (4) A and E only

Ans. 3

99. Match List I with List II

List I

- A. Decomposition
- B. Detritus
- C. Mineralisation
- D. Humification

List II

- I. Accumulation of dark coloured amorphous colloidal substance
- II. Release of inorganic nutrients by the activity of microbes in soil
- III. Breaking down of complex organic matter into inorganic substances
- IV. Dead remains of plants and animals including fecal matter

Choose the correct answer from the options given below:

- (1) A-I, B-II, C-III, D-IV
- (2) A-IV, B-III, C-I, D-II
- (3) A-III, B-IV, C-II, D-I
- (4) A-III, B-II, C-I, D-IV

Ans. 3

100. In which one of the following, the ovules are not enclosed by an ovary wall and remain exposed?

- (1) *Selaginella*
- (2) *Funaria*
- (3) *Pinus*
- (4) *Wolffia*

Ans. 3

101. Match List I with List II:

List I

(Placentation)

- A. Marginal
- B. Axile
- C. Parietal
- D. Basal

List II

(Example)

- I. Mustard
- II. Pea
- III. Marigold
- IV. Lemon

Choose the correct answer from the options given below:

- (1) A-I, B-III, C-II, D-IV
- (2) A-IV, B-II, C-I, D-III

(3) A-II, B-IV, C-I, D-III

(4) A-III, B-I, C-IV, D-II

Ans. 3

102. In angiosperms, root hairs arise from which one of the following regions of the root?

- (1) The root cap zone
- (2) The region of meristematic activity
- (3) The region of elongation
- (4) The region of maturation

Ans. 4

103. Which one of the following is not a characteristic of plant cells in the phase of elongation?

- (1) Increased vacuolation
- (2) Large conspicuous nuclei
- (3) Cell enlargement
- (4) New cell wall deposition

Ans. 2

104. Which of the following statements are correct with reference to a transcription unit?

- A. A transcription unit in DNA is defined primarily by three regions : promoter, structural gene and terminator.
- B. The promoter is said to be located towards the 5'-end of the structural gene.
- C. The promoter is a DNA sequence that provides binding site for RNA polymerase.
- D. The promoter defines the template and coding strands.
- E. The terminator is located towards the 3'-end of the coding strand and it defines the end of the process of transcription.

Choose the correct answer from the options given below:

- | | |
|------------------------|------------------------|
| (1) A, B, C, D and E | (2) B, C, D and E only |
| (3) A, C, D and E only | (4) A, B, C and D only |

Ans. 1

105. Alpha-helix is found in which level of protein structure?

- | | |
|--------------------------|-------------------------|
| (1) Quaternary structure | (2) Tertiary structure |
| (3) Primary structure | (4) Secondary structure |

Ans. 4

106. Which of the following statements are correct regarding amino acids?

- A. They are substituted methanes.
- B. Serine is an aromatic amino acid.
- C. Valine is a neutral amino acid.
- D. Lysine is an acidic amino acid.

Choose the correct answer from the options given below:

- | | |
|------------------|------------------|
| (1) C and D only | (2) A and B only |
| (3) A and C only | (4) B and C only |

Ans. 3

107. The main function of bulliform cells in grasses is:

- (1) to make the leaf impermeable to fungal spores.
- (2) to perform photosynthesis
- (3) to minimize water loss during water stress.
- (4) to transport water.

Ans. 3

108. Find the incorrect statement(s) about photosynthesis from the following:

- A. The water splitting complex is associated with PS I.
- B. C₄ plants use the C₃ pathway of CO₂ fixation as the main biosynthetic pathway.
- C. In C₄ plants, photorespiration does not occur.
- D. C₃ plants exhibit 'Kranz' anatomy.
- E. ATP synthesis in chloroplast occurs through chemiosmosis.

Choose the answer from the options given below:

- (1) B only
 (2) A and D only
 (3) B and C only
 (4) B and E only

Ans. 2

109. Match List I with List II:

List I

- A. Conjunctive tissue
 B. Casparian strips
 C. Subsidiary cells
 D. Starch sheath

List II

- I. Specialised cells in the vicinity of guard cells
 II. Endodermal cells rich in starch
 III. Tissue between xylem and phloem
 IV. Endodermal cells with suberin deposition

Choose the correct answer from the options given below:

- (1) A-IV, B-III, C-I, D-II
 (2) A-III, B-IV, C-II, D-I
 (3) A-III, B-IV, C-I, D-II
 (4) A-IV, B-III, C-II, D-I

Ans. 3

110. Match List I with List II:

List I

- A. Genetically modified organism
 B. Thermostable DNA polymerase
 C. Ti plasmid
 D. pBR322

List II

- I. *Agrobacterium tumefaciens*
 II. Bt cotton
 III. *Thermus aquaticus*
 IV. *Escherichia coli*

Choose the correct answer from the options given below:

- (1) A-II, B-I, C-IV, D-III
 (2) A-I, B-IV, C-III, D-II
 (3) A-II, B-III, C-I, D-IV
 (4) A-I, B-II, C-IV, D-III

Ans. 3

111. Heterophyllous development in response to environment is an example of which of the following phenomena?

- (1) Dedifferentiation
 (2) Elasticity
 (3) Redifferentiation
 (4) Plasticity

Ans. 4

112. In racemose inflorescence, _____

- (1) the main axis terminates in a flower
 (2) the growth is limited
 (3) flowers are borne in an acropetal succession
 (4) flowers are solitary

Ans. 3

113. Which one of the following disorders is caused by the substitution of Glutamic acid (Glu) by Valine (Val) at the sixth position of the beta globin chain of the haemoglobin molecule?

- (1) Haemophilia
 (2) Thalassemia
 (3) Sickle-cell anaemia
 (4) Phenylketonuria

Ans. 3

114. Match List I with List II:

List I

- A. Incomplete dominance
 B. Co-dominance
 C. Pleiotropy
 D. Polygenic inheritance

List II

- I. Human skin colour
 II. Inheritance of flower colour in *Antirrhinum* sp.
 III. Phenylketonuria disease in humans
 IV. ABO blood groups

Choose the correct answer from the options given below:

- (1) A-II, B-IV, C-III, D-I
 (2) A-I, B-III, C-II, D-IV
 (3) A-II, B-I, C-III, D-IV
 (4) A-I, B-IV, C-III, D-II

Ans. 1

115. Arrange the following in the correct developmental sequence related to microsporogenesis:

- A. Microspore tetrads

- B. Sporogenous tissue
- C. Pollen grains
- D. Pollen mother cells

Choose the correct answer from the options given below:

- (1) D, A, C, B
- (2) B, D, C, A
- (3) B, D, A, C
- (4) A, D, C, B

Ans. 3

116. Arrange the following steps of DNA fingerprinting in a correct sequence.

- A. Isolation of DNA and its digestion by restriction endonucleases.
- B. Hybridisation using a labelled VNTR probe.
- C. Transferring of separated DNA fragments to synthetic membranes.
- D. Detection of hybridised DNA fragments by autoradiography.
- E. Separation of DNA fragments by electrophoresis.

Choose the correct answer from the options given below:

- (1) A, E, C, B, D
- (2) A, E, B, C, D
- (3) A, E, B, C, D
- (4) A, D, B, E, C

Ans. 1

117. Exploring molecular, genetic and species-level diversity for products of economic importance is called:

- (1) Biomagnification
- (2) Biofortification
- (3) Bioremediation
- (4) Bioprospecting

Ans. 4

118. Which of the following statements are true with reference to the sex-determination in honeybees?

- A. An offspring formed from the union of a sperm and an egg, develops as a female (queen or worker).
- B. An unfertilized egg develops as a male by parthenogenesis.
- C. A male has half the number of chromosomes than that of a female.
- D. Males produce sperms meiosis.
- E. Honeybees have a haplodiploid sex-determination system.

Choose the correct answer form the options given below:

- (1) B, C, D and E only
- (2) A, B, C and D only
- (3) A, B, D and E only
- (4) A, B, C and E only

Ans. 4

119. Identify the correct sequence of steps in each cycle of Polymerase Chain Reaction:

- (1) Denaturation → Annealing → Extension
- (2) Denaturation → Extension → Annealing
- (3) Extension → Annealing → Denaturation
- (4) Annealing → Denaturation → Extension

Ans. 1

120. Which of the following statements are correct with respect to DNA separation, isolation and visualization?

- A. The cutting of DNA done by molecular scissors.
- B. The DNA fragments separate according to their size in an agarose gel, upon electrophoresis.
- C. The separated DNA fragments can be seen without staining when exposed to UV light.
- D. The separated DNA fragments, when stained with ethidium bromide, can be seen in visible light.

Choose the correct answer from the options given below:

- (1) A and D only
- (2) B and D only
- (3) B and C only
- (4) A and B only

Ans. 4

121. The main criteria used for Five Kingdom Classification proposed by R.H. Whittaker (1969) included:

- A. Cell structure
- B. Body organization
- C. Presence of flagellum
- D. Reproduction
- E. Phylogenetic relationships

Choose the correct answer from the options given below:

- (1) A, B, D and E only
- (2) A, B, C, D and E
- (3) A, B and E only
- (4) B, C and D only

Ans. 1

122. Which one of the following is a triploid cell?

- (1) Central cell
- (2) Primary endosperm cell
- (3) Zygote
- (4) Synergid

Ans. 2

123. Which of the following statements are correct with reference to packaging of DNA helix?

- A. Histones are organized to form a unit of eight molecules called histone octamer.
- B. Histones are negatively charged basic proteins.
- C. Histones are rich in the basic amino acid residues - lysine and arginine.
- D. The positively charged DNA is wrapped around the histone octamer to form nucleosome.
- E. The packaging of chromatin at higher levels requires an additional set of proteins called non-histone chromosomal proteins.

Choose the correct answer from the options given below:

- (1) A, B and D only
- (2) A, C and E only
- (3) C, D and E only
- (4) B, D and E only

Ans. 2

124. Which of the following is an *in situ* conservation method?

- (1) Sacred Groves
- (2) Wildlife Safari Parks
- (3) Botanical Gardens
- (4) Seed Banks

Ans. 1

125. In the lac operon, the *z* gene codes for:

- (1) transacetylase
- (2) the repressor of lac operon
- (3) permease
- (4) beta-galactosidase

Ans. 4

126. Match List I with List II:

List I
(Growth Regulator)

- A. 2,4-D
- B. GA₃
- C. Kinetin
- D. ABA

List II
(Function/Effect)

- I. Brewing industry
- II. Stimulation of stomatal closure
- III. Herbicide
- IV. Nutrient mobilisation

Choose the correct answer from the options given below:

- (1) A-IV, B-III, C-II, D-I
- (2) A-I, B-II, C-IV, D-III
- (3) A-III, B-I, C-IV, D-II
- (4) A-I, B-IV, C-III, D-II

Ans. 3

127. Arrange the following steps of somatic hybridisation in a correct sequence.

- A. Digestion of cell walls.
- B. Isolation of naked protoplasts.
- C. Fusion of protoplasts to get hybrid protoplast.
- D. Isolation of single cells from two different varieties of plants.
- E. Growing of hybrid protoplast to form a new plant.

Choose the correct answer from the options given below:

- (1) E, A, B, C, D
- (2) D, A, B, C, E
- (3) E, B, A, D, C
- (4) D, B, A, E, C

Ans. 2

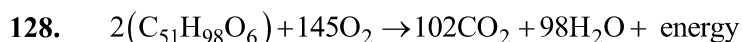

The Respiratory Quotient (RQ) of a biomolecule used for respiration, as per the above equation, would be:

- (1) Less than 0.5 (2) Between 0.5 and 0.95
 (3) Between 1.25 and 2 (4) 1.0

Ans. 2

129. Since the origin and diversification of life on Earth, there have been five episodes of mass extinction of species. How is the sixth extinction, which is in progress, different from the previous episodes?

- (1) The current species extinction rates are far lower than those in previous episodes.
 (2) The present species extinction rates are 100 to 1000 times faster than the pre-human times.
 (3) The present net species extinction rate is zero.
 (4) The current species extinction rate is nearly 10 times faster than that in previous episodes.

Ans. 2

130. Match List I with List II:

List I	List II
A. Trypsin	I. Intercellular ground substance
B. Morphine	II. Lectin
C. Concanavalin A	III. Enzyme
D. Collagen	IV. Alkaloid

Choose the correct answer from the options given below:

- (1) A-III, B-IV, C-II, D-I (2) A-I, B-II, C-III, D-IV
 (3) A-III, B-II, C-IV, D-I (4) A-IV, B-III, C-II, D-I

Ans. 1

131. Which one of the following statements is not true about the universal rules of binomial nomenclature?

- (1) Both the words in a biological name, when handwritten, are separately underlined or printed in italics.
 (2) The specific epithet in the biological name starts with a small letter.
 (3) The first word in the biological name represents the specific epithet, while the second component denotes the genus.
 (4) Biological names are generally in Latin.

Ans. 3

132. The enzyme required for carboxylation in the Calvin cycle is:

- (1) PEP carboxylase (2) RuBP carboxylase - oxygenase
 (3) Carboxypeptidase (4) Hexokinase

Ans. 2

133. Which of the following floral formula is the correct floral formula of Solanaceae family?

- (1) $\oplus \underset{\text{♀}}{\overset{\text{♂}}{\text{K}}}_{(5)} \overset{\text{♂}}{\text{C}}_{(5)} \text{A}_5 \underline{\text{G}}_{(2)}$
 (2) $\oplus \underset{\text{♀}}{\overset{\text{♂}}{\text{K}}}_5 \cdot \overset{\text{♂}}{\text{C}}_{(5)} \text{A}_5 \underline{\text{G}}_{(2)}$
 (3) $\oplus \underset{\text{♀}}{\overset{\text{♂}}{\text{K}}}_{(5)} \text{C}_{(5)} \text{A}_5 \underline{\text{G}}_{(2)}$
 (4) $\oplus \underset{\text{♀}}{\overset{\text{♂}}{\text{K}}}_5 \text{C}_5 \text{A}_5 \underline{\text{G}}_{(2)}$

Ans. 1

134. Which one of the following types of pollination brings genetically different types of pollen grains to the stigma?

- (1) Geitonogamy (2) Autogamy
 (3) Xenogamy (4) Cleistogamy

Ans. 3

135. Match List I with List II:

**List I
(Process)**

- A. Glycolysis
- B. ETS
- C. Accumulation of protons
- D. Krebs' cycle

**List II
(Location)**

- I. Inner mitochondrial membrane
- II. Mitochondrial matrix
- III. Cytoplasm
- IV. Intermembrane space

Choose the correct answer-from the options given below:

- (1) A-I, B-IV, C-III, D-II
- (2) A-III, B-I, C-IV, D-II -
- (3) A-IV, B-II, C-I, D-III
- (4) A-II, B-III, C-IV, D-I

Ans. 2

136. Insertion of a foreign DNA at BamHI site in an *E. coli* cloning vector pBR322 results in the loss of antibiotic resistance towards:

- (1) Gentamycin
- (2) Ampicillin and tetracycline
- (3) Tetracycline
- (4) Ampicillin

Ans. 3

137. The sixth mutant codon of beta globin gene causing polymerization of Haemoglobin and change in RBC shape is _____.

- (1) CAG
- (2) GUG
- (3) AUG
- (4) GAG

Ans. 2

138. Choose the correct statement regarding GIFT to overcome infertility.

- (1) Ova collected from a female donor are transferred to the uterus of an infertile female.
- (2) It is the transfer of an ovum collected from a donor into the fallopian tube of another female who cannot produce ovum but can provide suitable environment for fertilization and development.
- (3) Early embryos with up to 8 blastomeres are transferred to the uterus of an infertile female.
- (4) Early embryos with up to 8 blastomeres are transferred into the fallopian tube of an infertile female.

Ans. 2

139. Which one of the following is an appropriate example of 'sexual deceit'?

- (1) Female wasp and fig
- (2) Cuckoo and crow
- (3) Ophrys and bumblebee
- (4) Sea anemone and clown fish

Ans. 3

140. Evolution of human appears parallel to the progressive development of brain and language skills. As such, the evolution of individual species in the sequence of their appearance is :

- (1) *Homo habilis* → *Homo erectus* → *Ramapithecus* → *Neanderthal* → *Homo sapiens*
- (2) *Ramapithecus* → *Homo habilis* → *Homo erectus* → *Neanderthal* → *Homo sapiens*
- (3) *Homo sapiens* → *Ramapithecus* → *Homo habilis* → *Neanderthal* → *Homo erectus*
- (4) *Neanderthal* → *Ramapithecus* → *Homo habilis* → *Homo erectus* → *Homo sapiens*

Ans. 2

141. Match List I with List II related to embryonic development at various months of pregnancy:

List I

- A. The foetus movement starts and hair appears on the head
- B. The foetus develops limbs and digits
- C. The foetus develops external genital organs
- D. The foetus body is covered with fine hair; eyelids separate and eyelashes are formed

List II

- I. 24 weeks of pregnancy
- II. 20 weeks of pregnancy
- III. 8 weeks of pregnancy
- IV. 12 weeks of pregnancy

Choose the correct answer from the options given below:

- (1) A-III, B-II, C-IV, D-I (2) A-II, B-IV, C-III, D-I
 (3) A-IV, B-II, C-III, D-I (4) A-II, B-III, C-IV, D-I

Ans. 4

142. A group of researchers procured some fish-like animals and upon investigation the following characters were observed:

- A. Endoskeleton was made of cartilage.
 B. Ectoparasitic; as they were found attached on fish skin with their circular sucking mouth.
 C. Paired fins and scales were absent, but 7 pairs of gill slits were present.

Which of the following species of animals did they consider to fit best with these characters?

- (1) *Exocoetus sp.* (2) *Branchiostoma sp.*
 (3) *Petromyzon sp.* (4) *Scoliodon sp.*

Ans. 3

143. Spermatogonia undergo a series of cell divisions to produce sperms. Select the correct statements from the following:

- A. Spermatogonia always undergo meiotic cell division.
 B. Primary spermatocytes divide mitotically to produce secondary spermatocytes.
 C. Secondary spermatocytes, through their second meiotic division, produce haploid spermatids.
 D. Spermatids produce spermatozoa through mitosis.
 E. Spermatids transform into spermatozoa by spermiogenesis.

Choose the correct answer from the options given below:

- (1) C and E only (2) A, C and E only
 (3) B, C and D only (4) A and E only

Ans. 1

144. What is the probability of having children with 'O' blood group, where both mother and father are heterozygous for 'A' and 'B' blood group, respectively?

- (1) 50% (3) 75%
 (2) 0% (4) 25%

Ans. 4

145. Arrange the following events occurring in Renin-Angiotensin-mechanism in the correct order:

- A. Increase in blood pressure and Glomerular filtration rate.
 B. Reabsorption of Na^+ and water from distal parts of tubule due to Aldosterone.
 C. Fall in Glomerular filtration rate.
 D. Vasoconstriction by Angiotensin II and release of Aldosterone.
 E. Renin converts Angiotensinogen into Angiotensin I, followed by Angiotensin II.

Choose the correct answer from the options given below:

- (1) C, A, B, D, E (2) A, D, B, E, C
 (3) A, C, E, B, D (4) C, E, D, B, A

Ans. 4

146. Match List I with List II:

List I (Respiratory Volume)	List II (Capacity in mL)
A. ERV (Expiratory Reserve Volume)	I. 2500-3000 mL
B. RV (Residual Volume)	II. 500 mL
C. IRV (Inspiratory Reserve Volume)	III. 1000-1100 mL
D. TV (Tidal Volume)	IV. 1100-1200 mL

Choose the correct answer from the options given below:

- (1) A-III, B-I, C-IV, D-II (2) A-I, B-III, C-II, D-IV
 (3) A-III, B-IV, C-I, D-II (4) A-I, B-II, C-III, D-IV

Ans. 3

147. Match List I with List II:

List I	List II
A. Progestasert	I. Barrier made of rubber used by females
B. Multiload 375	II. Oral contraceptive

- C. Diaphragm
 D. Saheli
- III. Hormone releasing IUD
 IV. Copper releasing IUD

Choose the correct answer from the options given

- (1) A-III, B-IV, C-I, D-II
 (2) A-III, B-IV, C-II, D-I
 (3) A-IV, B-II, C-I, D-III
 (4) A-IV, B-III, C-I, D-II

Ans. 1

148. Non-membrane bound cell organelles found in both prokaryotic and eukaryotic cells are _____.

- (1) Centrosomes
 (2) Ribosomes
 (3) Lysosomes
 (4) Mitochondria

Ans. 2

149. Ecological pyramids represent the relationship between the organisms at different trophic levels and they are generally inverted for:

- (1) Pyramid of energy in pond ecosystem
 (2) Pyramid of biomass in sea
 (3) Pyramid of number in grassland
 (4) Pyramid of biomass in grassland

Ans. 2

150. The flightless bird with forelimbs modified as paddle-like structures suited for swimming is known as:

- (1) *Struthio*
 (2) *Psittacula*
 (3) *Neophron*
 (4) *Aptenodytes*

Ans. 4

151. Match List I with List II:

- | List I (Bioactive molecules) | List II (Importance) |
|------------------------------|---|
| A. Streptokinase | I. Immunosuppressive agent |
| B. Statins | II. Removal of clots from the blood vessels |
| C. Lipases | III. Blood cholesterol-lowering agent |
| D. Cyclosporin A | IV. Detergent formulations |

Choose the correct answer from the options given below:

- (1) A-II, B-III, C-IV, D-I
 (2) A-IV, B-III, C-II, D-I
 (3) A-II, B-III, C-I, D-IV
 (4) A-III, B-II, C-IV, D-I

Ans. 1

152. Choose the correct statements regarding cell organelles and their inclusions.

- A. The endomembrane system includes Golgi complex, endoplasmic reticulum and mitochondria.
 B. Rough endoplasmic reticulum bears ribosomes on its surface.
 C. Both mitochondria and plastids have circular DNA.
 D. A network of microtubules, microfilaments and intermediate filaments present in the cytoplasm is called cytoskeleton.
 E. Mitochondrion is a single membrane-bound structure.

Choose the correct answer from the options given below:

- (1) C, D and E only
 (2) A and B only
 (3) A, B and C only
 (4) B, C and D only

Ans. 4

153. Select the set of fishes which belong to the class Osteichthyes:

- (1) Devil fish, Cuttlefish and Hagfish
 (2) Starfish, Hagfish and Cuttlefish
 (3) Flying fish, Angel fish and Fighting fish
 (4) Saw fish, Fighting fish and Dog fish

Ans. 3

154. In a population of a grasshopper species, the chromosome number of some members is 23 and some other members possess 24 chromosomes. The 23 and 24 chromosome-bearing members in this species are _____.

- (1) all males (2) all females
 (3) females and males, respectively (4) males and females, respectively

Ans. 4

155. The WBC count of a person's blood sample is 8000/cu.mm. How many eosinophils and lymphocytes would be in the same blood sample approximately?

- (1) 160 -240/cu.mm and 1600 - 2000/cu.mm, respectively
 (2) 100 - 120/cu.mm and 160 - 200/cu.mm, respectively
 (3) 300 - 500/cu.mm and 500 - 700/cu.mm, respectively
 (4) 300 - 500/cu.mm and 1200 - 1500/cu.mm, respectively

Ans. 1

156. The toxin proteins isolated from *Bacillus thuringiensis*, coded by which of the following genes would control cotton bollworms and corn borer, respectively?

- (1) *cryIAC* and *cryIIIAb*
 (2) *cryIAC* and *cryIIAb*
 (3) *cryIAC* and *cryIAb*
 (4) *cryIIAB* and *cryIAC*

Ans. 3

157. Match List I with List II:

List I (Drug)

- A. Nicotine
 B. Morphine
 C. Heroin
 D. Cocaine

List II (Effect)

- I. Causes sense of euphoria and increased energy
 II. Stimulates adrenal gland to release catecholamines into blood circulation
 III. Effective sedative and painkiller
 IV. A depressant; slows down body function

Choose the correct answer from the options given below:

- (1) A-III, B-II, C-IV, D-I (2) A-II, B-III, C-IV, D-I
 (3) A-II, B-III, C-I, D-IV (4) A-III, B-II, C-I, D-IV

Ans. 2

158. Match List I with List II related to muscular/skeletal system:

List I

- A. Tetany
 B. Arthritis
 C. Myasthenia gravis
 D. Muscular dystrophy

List II

- I. Inflammation of joints
 II. Autoimmune disorder affecting neuromuscular junction
 III. Wild contraction in muscle due to low Ca^{++} in body fluid
 IV. Progressive degeneration of skeletal muscle

Choose the correct answer from the options given below:

- (1) A-III, B-I, C-II, D-IV (2) A-IV, B-III, C-II, D-I
 (3) A-I, B-II, C-III, D-IV (4) A-III, B-II, C-I, D-IV

Ans. 1

159. In which animal do haploid cells divide mitotically to produce gametes?

- (1) Male honeybees (2) Male grasshoppers
 (3) Male earthworms (4) Male frogs

Ans. 1

160. In humans, respiration occurs in the following steps. Arrange these steps in the correct order.

- A. Diffusion of O_2 and CO_2 between blood and tissues
 B. Diffusion of O_2 and CO_2 across alveolar membrane
 C. Pulmonary ventilation by which atmospheric air is drawn in and CO_2 rich alveolar air is released out
 D. Cellular respiration
 E. Transport of gases by the blood

Choose the correct answer from the options given below:

- (1) A, B, C, D, E (2) E, A, C, D, B
 (3) C, A, B, E, D (4) C, B, E, A, D

Ans. 4

161. Arrange the following cell layers/structures around the female gamete, from outer to inner side:

- A. Zona pellucida
- B. Perivitelline space
- C. Corona radiata
- D. Plasma membrane of ovum

Choose the correct answer from the options given below:

- (1) C, A, D, B
- (2) C, A, B, D
- (3) D, B, A, C
- (4) A, C, B, D

Ans. 2

162. The human protein named α -1-antitrypsin, obtained from transgenic animals, is used for the treatment of _____.

- (1) Alzheimer's disease
- (2) Emphysema
- (3) Rheumatoid arthritis
- (4) Cystic fibrosis

Ans. 2

163. Select the correct statements regarding cell membrane in eukaryotic cell.

- A. Membrane of human RBCs has approximately 52% protein.
- B. Major phospholipids are arranged in a bilayer.
- C. Extensions of the plasma membrane into the cell form mesosomes.
- D. Tails towards the inner part of lipids are hydrophobic and thus protected from aqueous medium.
- E. Glycocalyx is present on the outer surface of the plasma membrane

Choose the correct answer from the options given below:

- (1) A, C and E only
- (2) B, C and E only
- (3) C, D and E only
- (4) A, B and D only

Ans. 4

164. Male frogs can be distinguished from female frogs due to the presence of:

- A. Bulging eyes
- B. Vocal sacs
- C. Webbed digits in feet
- D. Copulatory pad on first digit of fore limbs
- E. Olive green-coloured skin with dark irregular spots

Choose the correct answer from the options given below:

- (1) B and D only
- (2) B and C only
- (3) A and B only
- (4) C and E only

Ans. 1

165. Which of the following equations depicts Verhulst-Pearl logistic population growth?

- (1) $\frac{dN}{dt} = rN \left(\frac{K - N}{K} \right)$
- (2) $\frac{dN}{dt} = rN \left(\frac{K + N}{K} \right)$
- (3) $\frac{dN}{dt} = rN \left(\frac{K}{K - N} \right)$
- (4) $\frac{dN}{dt} = rN \left(\frac{K - N}{N} \right)$

Ans. 1

166. Choose the correct statements regarding frog's anatomy:

- A. Hepatic portal system is the special venous connection between liver and intestine.
- B. There are twelve pairs of cranial nerves arising from the brain.
- C. The ureters and oviducts open separately into the cloaca in female frogs.
- D. Hind-brain consists of cerebellum, medulla oblongata and optic lobes.
- E. Sinus venosus joins the right atrium of heart.

Choose the correct answer from the options given below:

- (1) B and D only
- (2) A, C and E only
- (3) A, B and C
- (4) B and C only

Ans. 2

167. Select the incorrect statements with reference to Rh grouping.

- A. Erythroblastosis foetalis is a condition observed having foetus with Rh^{-ve} blood and mother with Rh^{+ve} blood.
- B. Rh antigen is observed on RBCs in the majority of human beings.
- C. Before blood transfusion, Rh group should also be matched.
- D. Rh incompatibility is observed when a pregnant mother is Rh^{-ve} and the foetus is Rh^{+ve}.
- E. Erythroblastosis foetalis can be avoided by administering anti-Rh antibodies to the mother immediately after the delivery of the second child.

Choose the answer from the options given below:

- (1) A and E only
- (2) A and B only
- (3) B and C only
- (4) C and D only

Ans. 1

168. Which of the following statements are correct with reference to human endoskeleton?

- A. Human skull is monocondylic.
- B. The joint between any two adjoining vertebrae is a cartilaginous joint.
- C. In human beings, the number of cervical vertebrae is seven.
- D. All ribs except the last 2 pairs are bicephalic.
- E. The occipital bone of skull is articulated with atlas vertebra.

Choose the correct answer from the options given below:

- (1) A, B and D only
- (2) B and E only
- (3) B, C and E only
- (4) C, D and E only

Ans. 3

169. Match List I with List II:

List I

- A. Cortisol
- B. Aldosterone
- C. Cholecystokinin
- D. Progesterone

List II

- I. Stimulates the formation of alveoli in mammary glands
- II. Produces anti-inflammatory reactions
- III. Stimulates reabsorption of Na⁺ and water from renal tubule
- IV. Stimulates secretion of pancreatic enzymes and bile juice

Choose the correct answer from the options given below:

- (1) A-III, B-II, C-IV, D-I
- (2) A-II, B-III, C-IV, D-I
- (3) A-IV, B-II, C-I, D-III
- (4) A-II, B-III, C-I, D-IV

Ans. 2

170. The following are the stages of life cycle of Plasmodium. Arrange the stages in the proper order.

- A. The parasites reproduce asexually in RBCs, bursting the cells.
- B. The parasites reproduce asexually in liver cells, bursting the cells and releasing into blood.
- C. Gametocytes develop in RBCs.
- D. Sporozoites reach the liver through the blood.
- E. Female mosquito injects sporozoites into humans during bite.

Choose the correct answer from the options given below:

- (1) A, B, C, D, E
- (2) E, D, B, A, C
- (3) C, A, B, D, E
- (4) E, C, D, B, A

Ans. 2

171. Select the incorrect statements from the following:

- A. Digestive system in Platyhelminthes is incomplete.
- B. Bilateral symmetry is a characteristic feature of adult Echinoderms.
- C. Pseudocoelom is possessed by Aschelminthes.
- D. Notochord is persistent throughout life in the class Chondrichthyes.
- E. Members of class Reptilia maintain a constant body temperature.

Choose the answer from the options given below:

- (1) B and E only
- (2) C and D only
- (3) A and C only
- (4) B and D only

Ans. 1

172. The specific receptors for neurotransmitters in a synapse are present on _____.
- (1) Post-synaptic membrane (2) Pre-synaptic membrane
(3) Myelin sheath (4) Schwann cell

Ans. 1

173. Choose the correct statements regarding muscle contraction.
- A. A motor neuron carries a signal sent by the Central Nervous System (CNS) to the sarcolemma of the muscle fibre.
B. The neural signal generates an action potential when causes the release of Ca^{++} into sarcoplasm.
C. Increase in Ca^{++} inactivates the actin for breaking cross bridges.
D. Actin binds to the myosin head to form a cross bridge.
E. Shortening of sarcomere takes place, by pulling actin filaments towards the centre of 'A' band.

Choose the correct answer from the options given below:

- (1) A, B, D and E only (2) C and D only
(3) C and E only (4) A and B only

Ans. 1

174. Which of the following is not an example of convergent evolution?
- (1) Eyes of octopuses and mammals
(2) Fore limbs of whales and bats
(3) Wings of butterflies and birds
(4) Flippers of penguins and dolphins

Ans. 2

175. The JGA (Juxta Glomerular Apparatus) is a special sensitive region formed by cellular modifications in _____ related to the same nephron.
- (1) Distal convoluted tubule and efferent renal arteriole
(2) Proximal convoluted tubule and afferent renal arteriole
(3) Distal convoluted tubule and afferent renal arteriole
(4) Proximal convoluted tubule and efferent renal arteriole

Ans. 3

176. The following reaction depicts the activity of a particular class of enzymes:

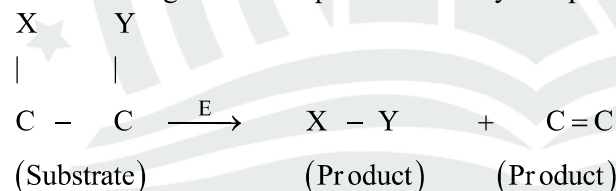

Identify the enzyme class 'E' from the following options:

- (1) Ligases (2) Lyases
(3) Isomerases (4) Transferases

Ans. 2

177. Match List I with List II:

List I	List II
A. Molluscs	I. Pulmonary respiration only
B. Reptiles	II. Branchial respiration
C. Adult amphibians	III. Cellular respiration
D. <i>Amoeba</i>	IV. Pulmonary and Cutaneous respiration

Choose the correct answer from the options given below:

- (1) A-III, B-II, C-I, D-IV (2) A-II, B-I, C-IV, D-III
(3) A-II, B-I, C-III, D-IV (4) A-I, B-II, C-IV, D-III

Ans. 2

178. What is the reason behind production of large holes in 'Swiss Cheese'?
- (1) The productions of large amount of CO_2 by *Clostridium butylicum*
(2) The production of large amount of CO_2 and H_2 by *Trichoderma polysporum*

(3) The production of large amount of CO₂ and H₂ by lactic acid bacteria called *Lactobacillus*

(4) The production of large amount of CO₂ by *Propionibacterium sharmanii*

Ans. 4

179. Match List I with List II with respect to chronology of evolution of life forms:

List I

- A. About 65 mya
- B. About 500 mya
- C. About 350 mya
- D. About 320 mya

List II

- I. Jawless fish probably evolved
- II. The dinosaurs suddenly disappeared from the earth
- III. Seaweeds and few plants probably existed
- IV. Invertebrates were formed and became active

Choose the correct answer from the options given below:

(1) A-II, B-IV, C-I, D-III

(2) A-II, B-IV, C-III, D-I

(3) A-I, B-II, C-III, D-IV

(4) A-III, B-IV, C-I, D-II

Ans. 1

180. Choose the correct statements regarding population interactions between two species.

A. In both parasitism and commensalism, only one species benefits and the other species is harmed.

B. Both species benefit in mutualism.

C. Both species benefit in commensalism.

D. In parasitism, only one species benefits and the other species is harmed.

E. In amensalism, one species is harmed and the other is unaffected.

Choose the correct answer from the options given below:

(1) A and D only

(2) A and B only

(3) B and E only

(4) B, D and E only

Ans. 4



NARAYANA NATIONAL RESULT

TRIUMPHANT SUCCESS

in **NEET (UG)-2024**

MARKS

720

720



1st

AIR

PRACHITA

Online Crash Course
(Distance Learning Programme)

MARKS

715

720



AIR

28th

ARINDAM CHOWDHURY
Online Crash Course
(Distance Learning Programme)

MARKS

715

720



AIR

37th

TANISHK YADAV
1 Year Classroom Programme

MARKS

715

720



AIR

41st

ADITYA KUMAR PANDA
Online Crash Course
(Distance Learning Programme)

MARKS

715

720



AIR

43rd

ISHA KOTHARI
Online Crash Course
(Distance Learning Programme)

MARKS

715

720



AIR

44th

K SANDEEP CHOWDARY
4 Years Classroom Programme

MARKS

715

720



AIR

45th

SHASHANK SHARMA
1 Year Classroom Programme

MARKS

715

720



AIR

60th

KRISHNAMURTI P S
Online Crash Course
(Distance Learning Programme)

MARKS

715

720



AIR

64th

SAM SHREYAS JOSEPH
2 Years Classroom Programme

MARKS

715

720



AIR

76th

DARSH PAGHDAR
Online Crash Course
(Distance Learning Programme)

MARKS

715

720



AIR

80th

RISHABH SHAH
Online Crash Course
(Distance Learning Programme)

MARKS

715

720



AIR

91st

SOHAM SHANKANT GAYKAR
Online Crash Course
(Distance Learning Programme)

MARKS

715

720



AIR

103rd

D N NITHIN
4 Years Classroom Programme

NARAYANA OPERATIONS ACROSS INDIA



23 STATES



950+ SCHOOLS,
COLLEGES &
COACHING CENTERS



6 LAKH+ LEARNERS
ANNUALLY



9 PROFESSIONAL
COLLEGES



50,000+
EMPLOYEES

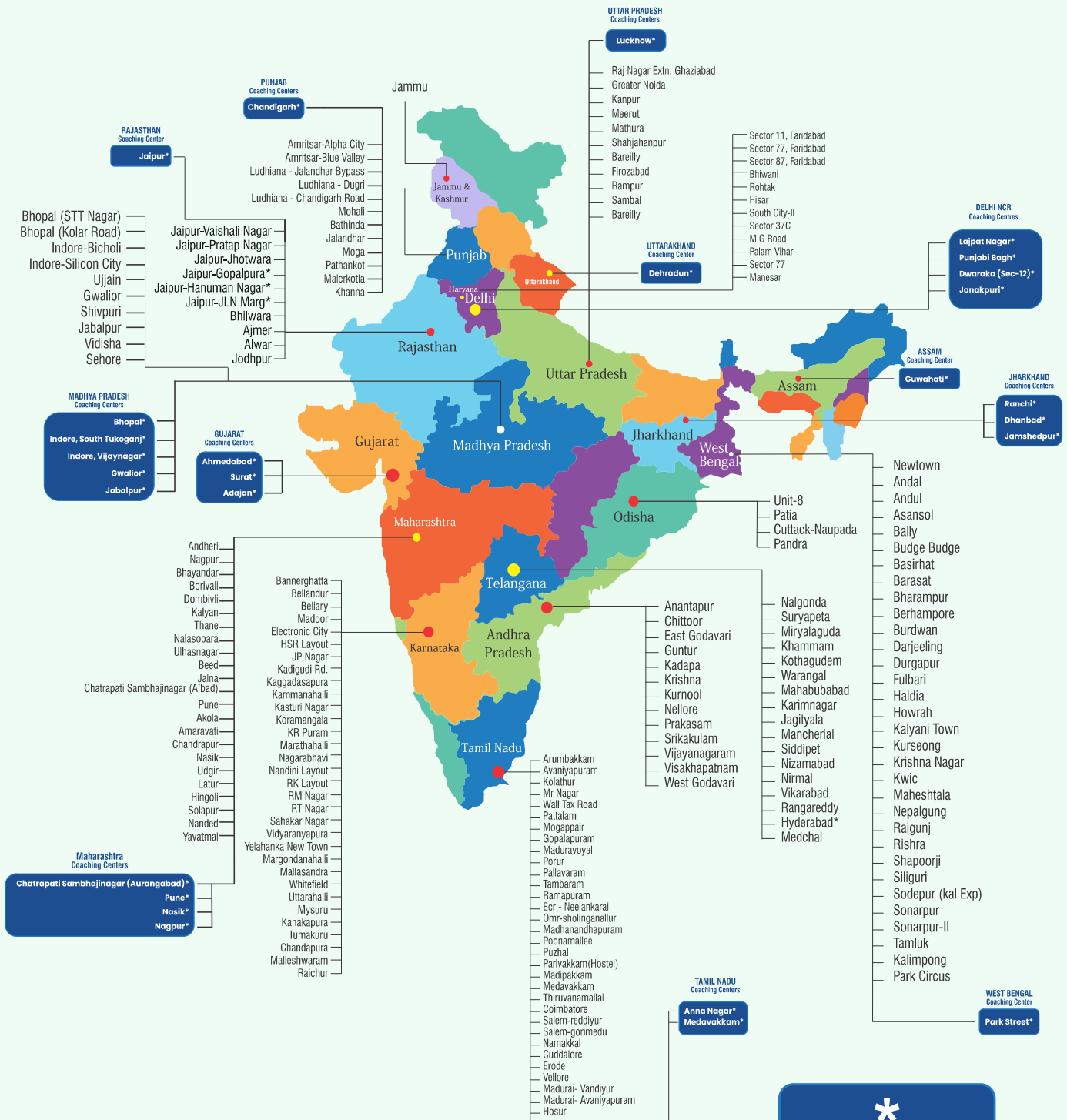

**IT-JEE/NEET/FOUNDATION
COACHING CENTERS**

Printed and Published by:

Nspira Management Services Pvt. Ltd.

Address: Door No 8-84/14/6/3, Devaryamzal Village,
Shamirpet Mandal, Medchal District, Telangana State-500 078

www.nspira.in



Toll Free: 1800 102 3344



SUBSCRIBE /TheNarayanaGroup